

Qualification Exam: Classical Mechanics

Name: _____, QEID#95017014:

October, 2023

1 Undergraduate level

Problem 1. *Skier on sphere* ID:CM-U-1

A skier starts from the top of a semi-sphere of radius R with negligible initial velocity. There is no friction or air resistance.

1. At what angle ϕ_0 measured as shown on the figure the skier will lift off?
2. What will be this angle if the skier is on the Moon?

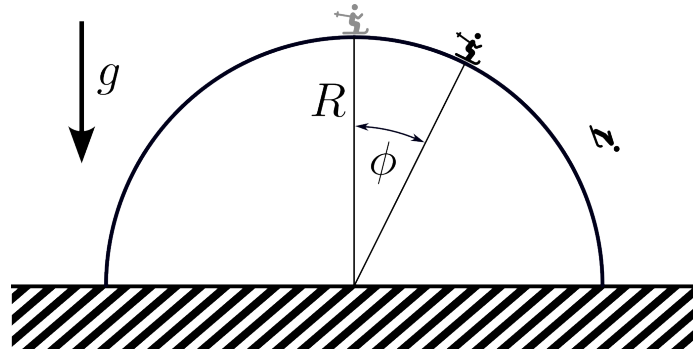

Problem 2. *1983-Fall-CM-U-1.* ID:CM-U-2

1. Consider a particle of mass m moving in a plane under the influence of a spherically symmetric potential $V(r)$.
 - i) Write down the Lagrangian in plane polar coordinates r, θ .
 - ii) Write down Lagrange's equations in these coordinates.
 - iii) What are the constants of the motion (conserved quantities).
 - iv) Derive an equation for the orbit $\theta(r)$, in the form $\theta(r) = \int f(r)dr$. The function $f(r)$ will involve $V(r)$.
2. Consider a particle of mass m moving in a plane in the potential $V(r, \dot{r}) = \frac{e^2}{r}(1 + \dot{r}^2/c^2)$, where c and e are constants. Obtain the Hamiltonian. Your answer should be in terms of the polar coordinates r and θ and their conjugate momenta P_r and P_θ .

Problem 3. *1983-Fall-CM-U-2.* ID:CM-U-15

Take $K = 4k$ and $m_1 = m_2 = M$. At $t = 0$ both masses are at their equilibrium positions, m_1 has a velocity v_0 to the right, and m_2 is at rest. Determine

1. The distance, x_1 , of m_1 from its equilibrium position at time $t = \frac{\pi}{4}\sqrt{\frac{M}{k}}$.
2. The ratio $\frac{x_1(t_0)}{x_2(t_0)}$, where $t_0 = \frac{\pi}{4}\sqrt{\frac{M}{k}}$.

Hint: First find the normal modes and the normal mode frequencies, then put in the initial conditions.

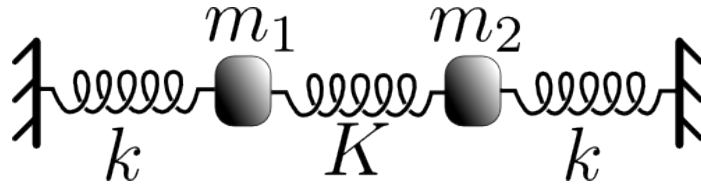

Problem 4. 1983-Fall-CM-U-3.

ID:CM-U-22

A hollow thin walled cylinder of radius r and mass M is constrained to roll without slipping inside a cylindrical surface with radius $R + r$ (see diagram). The point B coincides with the point A when the cylinder has its minimum potential energy.

1. What is the frequency of small oscillations around the equilibrium position?
2. What would the frequency of small oscillations be if the contact between the surfaces is frictionless?

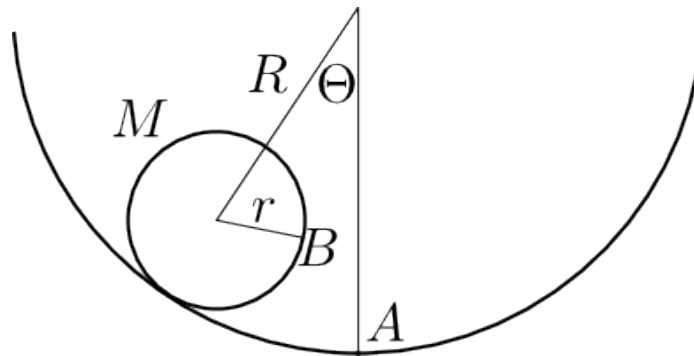

Problem 5. 1983-Spring-CM-U-1.

ID:CM-U-33

A ball, mass m , hangs by a massless string from the ceiling of a car in a passenger train. At time t the train has velocity \vec{v} and acceleration \vec{a} in the same direction. What is the angle that the string makes with the vertical? Make a sketch which clearly indicates the relative direction of deflection.

Problem 6. 1983-Spring-CM-U-2.

ID:CM-U-37

A ball is thrown vertically upward from the ground with velocity \vec{v}_0 . Assume air resistance exerts a force proportional to the velocity. Write down a differential equation for the position. Rewrite this equation in terms of the velocity and solve for $\vec{v}(t)$. Does your solution give the correct result for $t \rightarrow \infty$? What is the physical meaning of this asymptotic value? Would you expect the time during which the ball rises to be longer or shorter than the time during which it falls back to the ground?

Problem 7. 1983-Spring-CM-U-3.

ID:CM-U-42

Two metal balls have the same mass m and radius R , however one has a hollow in the center (they are made of different materials). If they are released simultaneously at the top of an inclined plane, which (if either) will reach the bottom of the inclined plane first? You must explain your answer with quantitative equations. What happens if the inclined plane is frictionless?

Problem 8. 1984-Fall-CM-U-1.

ID:CM-U-47

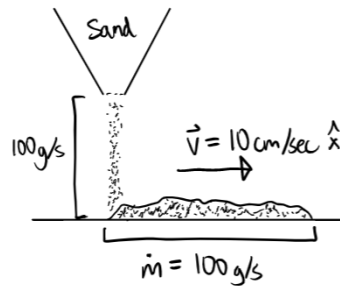

Sand drops vertically from a stationary hopper at a constant rate of 100 gram per second onto a horizontal conveyor belt moving at a constant velocity, \vec{v} , of 10 cm/sec.

1. What force (magnitude and direction relative to the velocity) is required to keep the belt moving at a constant speed of 10 cm/sec?
2. How much work is done by this force in 1.0 second?
3. What is the change in kinetic energy of the conveyor belt in 1.0 second due to the additional sand on it?
4. Should the answers to parts 2. and 3. be the same? Explain.

Problem 9. 1984-Fall-CM-U-2.

ID:CM-U-59

Two forces \mathbf{F}^A and \mathbf{F}^B have the following components

$$\mathbf{F}^A : \begin{cases} F_x^A = 6abyz^3 - 20bx^3y^2 \\ F_y^A = 6abxz^3 - 10bx^4y \\ F_z^A = 18abxyz^2 \end{cases}, \quad \mathbf{F}^B : \begin{cases} F_x^B = 18abyz^3 - 20bx^3y^2 \\ F_y^B = 18abxz^3 - 10bx^4y \\ F_z^B = 6abxyz^2 \end{cases}$$

Which one of these is a conservative force? Prove your answer. For the conservative force determine the potential energy function $V(x, y, z)$. Assume $V(0, 0, 0) = 0$.

Problem 10. 1984-Fall-CM-U-3.

ID:CM-U-80

1. What is canonical transformation?
2. For what value(s) of α and β do the equations

$$Q = q^\alpha \cos(\beta p), \quad P = q^\alpha \sin(\beta p)$$

represent a canonical transformation? Assume that α and β are constants.

Problem 11. *1984-Spring-CM-U-1.*

ID:CM-U-91

1. A small ball of mass m is dropped immediately behind a large one of mass M from a height h much larger than the size of the balls. What is the relationship between m and M if the large ball stops at the floor? Under this condition, how high does the small ball rise? Assume the balls are perfectly elastic and use an independent collision model in which the large ball collides elastically with the floor and returns to strike the small ball in a second collision that is elastic and independent from the first.
2. It is possible to construct a stack of books leaning over the edge of a desk as shown. If the stack is not to tip over, what is the condition on the center of mass of all the books above any given book? Consider identical books of width W . For a single book, the maximum overhang (distance extending over the edge of the desk) is obviously $W/2$. What is the maximum overhang, L , for a stack of 2 books? 3 books? 4 books? By extrapolation write a general formula for L for N books.

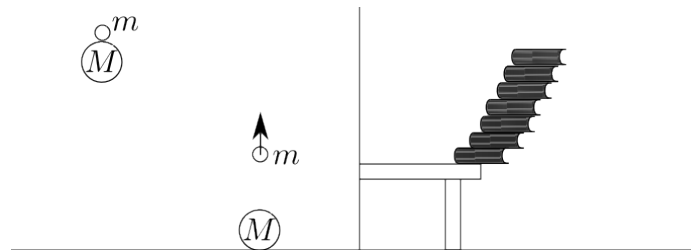
**Problem 12.** *1984-Spring-CM-U-2.*

ID:CM-U-101

A particle of mass m moves subject to a central force whose potential is $V(r) = Kr^3$, $K > 0$.

1. For what kinetic energy and angular momentum will the orbit be a circle of radius a about the origin?
2. What is the period T of this circular motion?
3. If the motion is slightly disturbed from this circular orbit, what will be the period τ of small radial oscillations about $r = a$? Express τ through T . (Assume that the disturbance is in the radial direction.)

Problem 13. *1984-Spring-CM-U-3.*

ID:CM-U-110

1. Find a kinetic energy T in 2-dimensions using polar coordinates (r, θ) , starting with $T = \frac{m}{2}(\dot{x}^2 + \dot{y}^2)$.
2. **For the rest of this problem, let the potential energy $V(r, \theta, t) = \frac{A}{r^2}f(\theta - \omega t)$, where A and ω are constants.** Write down the Lagrangian L , then determine the conjugate momenta p_r and p_θ .

3. Find the Hamiltonian $H(\theta, p_\theta, r, p_r, t)$. Does H represent the total energy, $T+V$?
4. Is energy, angular momentum or linear momentum a constant of the motion? Give a reason in each case.
5. Now use r and $\alpha = \theta - \omega t$ as variables. Find p_r and p_α , and $H(\alpha, p_\alpha, r, p_r, t)$.
6. Does $H' = H$? Does H' represent the total energy? What constants of motion can you identify?

Problem 14. 1985-Fall-CM-U-2.

ID:CM-U-128

A straight rod of length b and weight W is composed of two pieces of equal length and cross section joined end-to-end. The densities of the two pieces are 9 and 1. The rod is placed in a smooth, fixed hemispherical bowl of radius R . ($b < 2R$).

1. Find expression for the fixed angle β between the rod and the radius shown in Fig.1
2. Find the position of the center of mass when the rod is horizontal with its denser side on the left (Fig. 1). Give your answer as a distance from the left end.
3. Show that the angle θ which the rod makes with the horizontal when it is in equilibrium (Fig. 2) satisfies

$$\tan \theta = \frac{2}{5} \frac{1}{\sqrt{(2R/b)^2 - 1}}$$

Note the fundamental principles you employ in this proof.

4. Show that the equilibrium is stable under small displacements.

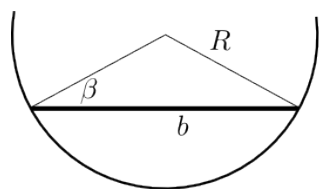

Fig. 1

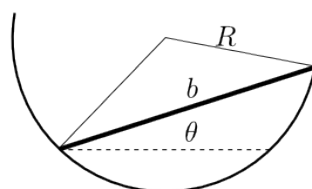
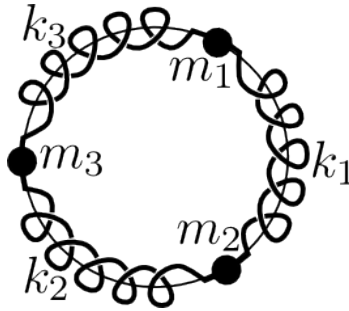

Fig. 2

Problem 15. 1985-Fall-CM-U-3.

ID:CM-U-147

Three particles of the same mass $m_1 = m_2 = m_3 = m$ are constrained to move in a common circular path. They are connected by three identical springs of stiffness $k_1 = k_2 = k_3 = k$, as shown. Find the normal frequencies and normal modes of the system.



Problem 16. 1985-Spring-CM-U-1. ID:CM-U-154

Consider a mass m moving without friction inside a vertical, frictionless hoop of radius R . What must the speed V_0 of a mass be at a bottom of a hoop, so that it will slide along the hoop until it reaches the point 60° away from the top of the hoop and then falls away?

Problem 17. 1985-Spring-CM-U-2. ID:CM-U-159

Two cylinders having radii R_1 and $R_2 < R_1$ and rotational inertias I_1 and I_2 respectively, are supported by fixed axes perpendicular to the plane of the figure. The large cylinder is initially rotating with angular velocity ω_0 . The small cylinder is moved until it touches the large cylinder and is caused to rotate by the frictional force between the two. Eventually, slipping ceases, and the two cylinders rotate at constant rates in opposite directions. Find the final angular velocity ω_2 of the small cylinder in terms of I_1 , I_2 , R_1 , R_2 , and ω_0 .

Problem 18. 1985-Spring-CM-U-3. ID:CM-U-164

A damped one-dimensional linear oscillator is subjected to a periodic driving force described by a function $F(t)$. The equation of motion of the oscillator is given by

$$m\ddot{x} + b\dot{x} + kx = F(t),$$

where $F(t)$ is given by

$$F(t) = F_0 (1 + \sin(\omega t)).$$

The driving force frequency is $\omega = \omega_0$ and the damping by $b/2m = \omega_0$, where $\omega_0^2 = k/m$. At $t = 0$ the mass is at rest at the equilibrium position, so that the initial conditions are given by $x(0) = 0$, and $\dot{x}(0) = 0$. Find the solution $x(t)$ for the position of the oscillator vs. time.

Problem 19. 1986-Spring-CM-U-1. ID:CM-U-177

A mass m hangs vertically with the force of gravity on it. It is supported in equilibrium by two different springs of spring constants k_1 and k_2 respectively. The springs are to be considered ideal and massless.

Using your own notations (clearly defined) for any coordinates and other physical quantities you need develop in logical steps an expression for the net force on the mass if it is displaced vertically downward a distance y from its equilibrium position. (Clarity and explicit expression of your physical reasoning will be important in the evaluation of your solution to this problem. Express your result through y , k_1 , k_2 .)

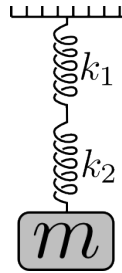

Problem 20. 1986-Spring-CM-U-2. ID:CM-U-188

A “physical pendulum” is constructed by hanging a thin uniform rod of length l and mass m from the ceiling as shown in the figure. The hinge at ceiling is frictionless and constrains the rod to swing in a plane. The angle θ is measured from the vertical.

1. Find the Lagrangian for the system.
2. Use Euler-Lagrange differential equation(s) to find the equation(s) of motion for the system. (BUT DON'T SOLVE).
3. Find the approximate solution of the Euler-Lagrange differential equation(s) for the case in which the maximum value of θ is small.
4. Find the Hamiltonian $H(p, q)$ for the system.
5. Use the canonical equations of Hamilton to find the equations of motion for the system and solve for the case of small maximum angle θ . Compare your results with b. and c.

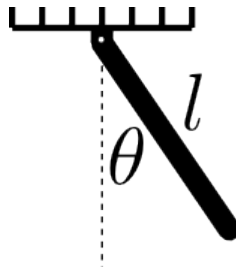

Problem 21. 1986-Spring-CM-U-3. ID:CM-U-205

Two masses $m_1 = m_2 = m$ are in equilibrium at the positions shown. They are connected together by three springs, two with spring constants k , and one with spring constant K . The masses move across a horizontal surface without friction.

1. Disconnect the center spring from the left mass. Isolate the left mass, draw the force vectors on the mass, and use the Newton's Law to get the differential equation of motion. Solve the equation and find the angular frequency ω_0 for the vibration.
2. With all the springs connected write down the equations of motion for the two masses in terms of x_1 and x_2 , again using the Newton's Law.

3. Find the normal modes of the vibration and calculate their associated eigenfrequencies.

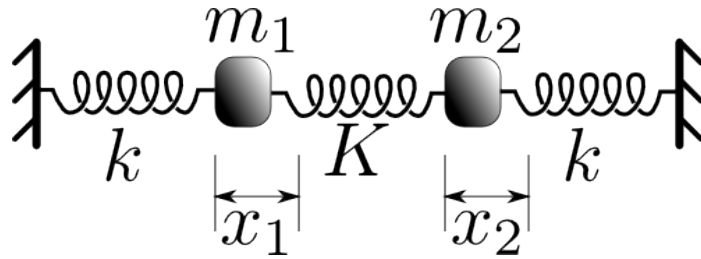

Problem 22. 1987-Fall-CM-U-1.

ID:CM-U-219

A block of mass m slides on a frictionless table with velocity v . At $x = 0$, it encounters a frictionless ramp of mass $m/2$ which is sitting at rest on the frictionless table. The block slides up the ramp, reaches maximum height, and slides back down.

1. What is the velocity of the block when it reaches its maximum height?
2. How high above the frictionless table does the block rise?
3. What are the final velocities of the block and the ramp?

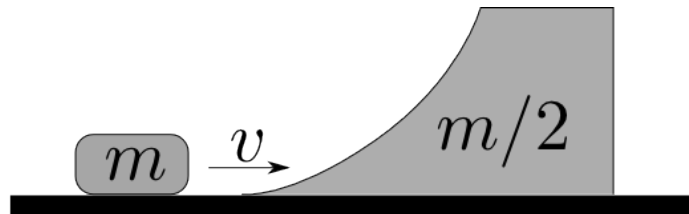

Problem 23. 1987-Fall-CM-U-2.jpg

ID:CM-U-233

A massless rope winds around a cylinder of mass M and radius R , over a pulley, and then wraps around a solid sphere of mass M and radius R . The pulley is a hoop, also of mass M and radius R , and is free to turn about a frictionless bearing located at its center. The rope does not slip on the pulley. Find the linear accelerations a_1 and a_2 of the centers of the sphere and cylinder respectively, and the angular acceleration α of the pulley. The positive directions for a_1 , a_2 , and α are shown in the figure.

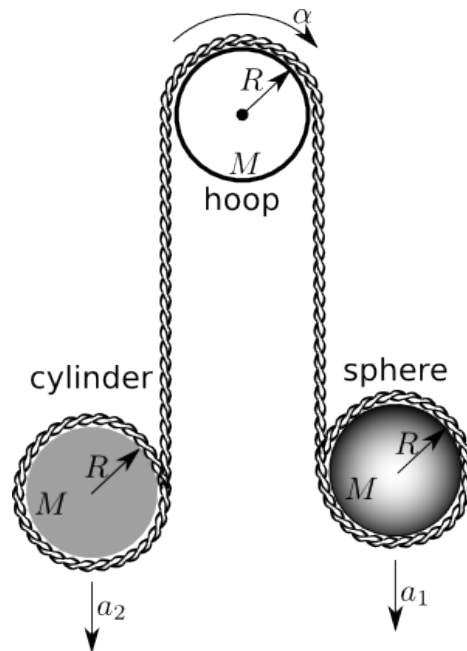

Problem 24. *1987-Fall-CM-U-3.*

ID:CM-U-242

A rigid body has three different principal moments of inertia $I_1 > I_2 > I_3$. Show that rotations about the 1 and 3 axes are stable, while rotation about the 2 axis is unstable. Define what you mean by stability.

Problem 25. *1988-Fall-CM-U-1.*

ID:CM-U-247

A bucket of mass M is being drawn up a well by a rope which exerts a steady force P on the bucket. Initially the bucket is at rest and contains a total mass m of water, but this leaks out at a constant rate, so that after a time T , before the bucket reaches the top, the bucket is empty. Find the velocity of the bucket just at the instant it becomes empty.

Express your answer in terms of P , M , m , T , and g , the acceleration due to gravity.

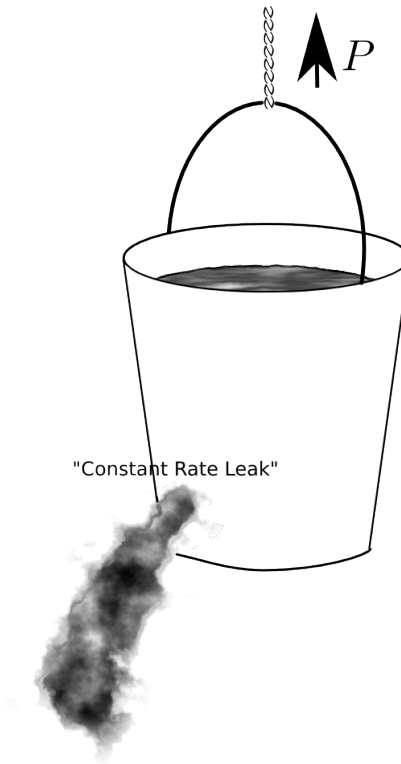

Problem 26. *1988-Fall-CM-U-2.*

ID:CM-U-258

A string of beads, which are tied together and have a total length L , is suspended in a frictionless tube as shown in the figure. Consider the beads to have a mass per unit length μ . The tube is supported so that it will not move. Initially the beads are held with the bottom most bead at the bottom of the vertical section of the tube, as shown in the figure. The beads are then released at time $t = 0$.

Find the horizontal force exerted against the tube by the beads after they have fallen a vertical distance x .

(Assume that L is much larger compared to the radius of the curvature of the tube.)

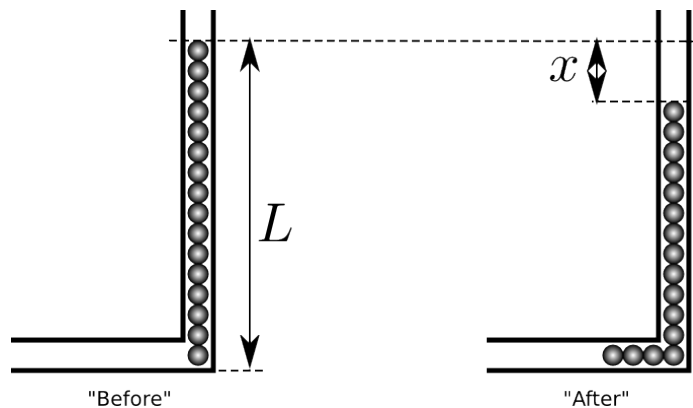

Problem 27. 1989-Fall-CM-U-1.

ID:CM-U-274

Two equal masses m are connected by a string of force constant k . They are restricted to motion in the \hat{x} direction.

1. Find the normal mode frequencies.
2. A leftward impulse P is suddenly given to the particle on the right. How long does it take for the spring to reach maximum compression?
3. How far does the mass on the left travel before the spring reaches maximum compression?

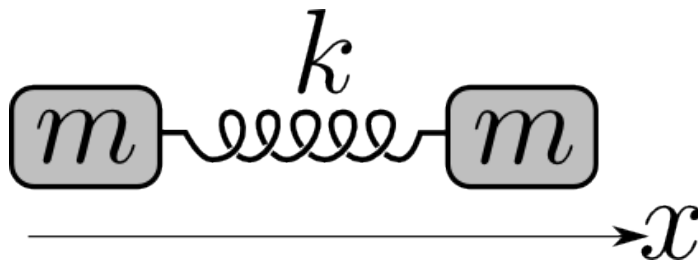

Problem 28. 1989-Fall-CM-U-2.jpg

ID:CM-U-288

A ball is on a frictionless table. A string is connected to the ball as shown in the figure. The ball is started in a circle of radius R with angular velocity v_0 . The force exerted on a string is then increased so that the distance between the hole and the ball decreases according to

$$r(t) = R - a_1 t^2$$

where a_1 is a constant. Assuming the string stays straight and that it only exerts a force parallel to its length.

1. Find the velocity of the ball as a function of time.
2. What must a_1 be for the assumption about the force to be valid?

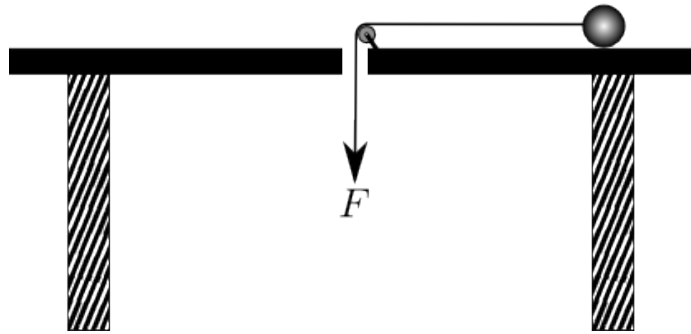

Problem 29. 1989-Fall-CM-U-3.

ID:CM-U-304

A stream of incompressible and non-viscous fluid of density ρ (kilograms per cubic meter) is directed at angle θ below the horizontal toward a smooth vertical surface as shown in the figure. The flow from the nozzle of cross section a (square meters) is uncomplicated by nozzle aperture effects. The beaker below the vertical surface, which catches all the fluid, has a uniform cross section A (square meters). During the experiment the fluid level in the beaker rises at a uniform speed of v (meters per second). What horizontal force is exerted by the stream of fluid on the vertical surface? The horizontal distance from the spout opening and the wall is d (meters). Give your final result in terms of the notation used in the problem statement and any other notation you think you need to define.

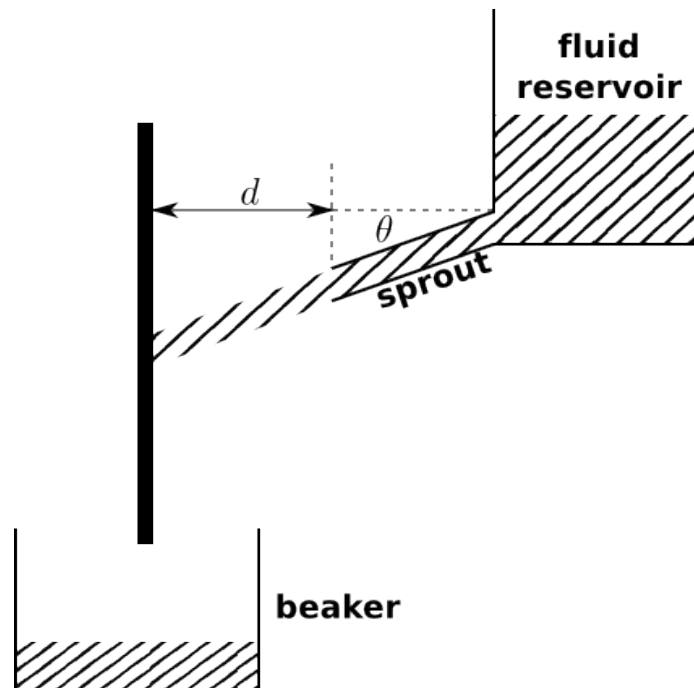

Problem 30. 1989-Spring-CM-U-1. ID:CM-U-313

A particle of mass m scatters off a second particle with mass M according to a potential

$$U(r) = \frac{\alpha}{r^2}, \quad \alpha > 0$$

Initially m has a velocity v_0 and approaches M with an impact parameter b . Assume $m \ll M$, so that M can be considered to remain at rest during the collision.

1. Find the distance of closest approach of m to M .
2. Find the laboratory scattering angle. (Remember that M remains at rest.)

Problem 31. 1989-Spring-CM-U-2. ID:CM-U-327

A platform is free to rotate in the horizontal plane about a frictionless, vertical axle. About this axle the platform has a moment of inertia I_p . An object is placed on a platform a distance R from the center of the axle. The mass of the object is m and it is very small in size. The coefficient of friction between the object and the platform is μ . If at $t = 0$ a torque of constant magnitude τ_0 about the axle is applied to the platform when will the object start to slip?

Problem 32. 1989-Spring-CM-U-3. ID:CM-U-332

A coupled oscillator system is constructed as shown, $m_1 = m$, and $m_2 = 2m$. Assume that the two springs are massless, and that the motion of the system is only in one dimension with no damping.

1. Find the eigenfrequencies and eigenvectors of the system.
2. Let L_1 and L_2 be the equilibrium positions of masses 1 and 2, respectively. Find the solution for all times $t \geq 0$ for $x_1(t)$ and $x_2(t)$ for the initial conditions:

$$\begin{aligned} x_1(t=0) &= L_1; & dx_1/dt &= -V_0 \quad \text{at } t=0 \\ x_2(t=0) &= L_2; & dx_2/dt &= 0 \quad \text{at } t=0. \end{aligned}$$

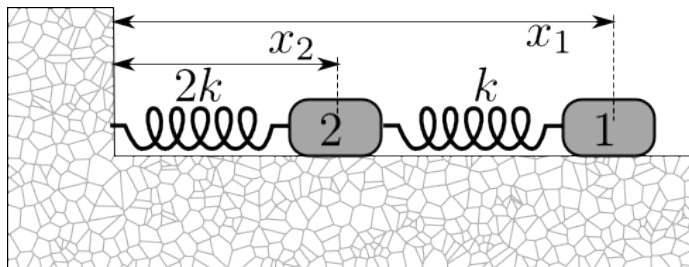

Problem 33. 1990-Fall-CM-U-1. ID:CM-U-348

A small steel ball with mass m is originally held in place by hand and is connected to two identical horizontal springs fixed to walls as shown in the left figure. The two springs are **unstretched** with natural length L and spring constant k . If the ball is now let go, it will begin to drop and when it is at a distance y below its original position each spring will stretch by an amount x as shown in the right figure. It is observed that the amount of stretching x is very small in comparison to L .

1. Write down the equation that determines $y(t)$. (Take y to be positive in going downward.) Is this simple harmonic motion?
2. Find the equilibrium position y_{eq} about which the steel ball will oscillate in terms of m , g , k , and L .
3. Find the maximum distance, y_{max} , that the steel ball can drop below its original position in terms of m , g , k , and L .
4. Write down an expression for the period of the steel ball's motion. (DO NOT evaluate the integral.)

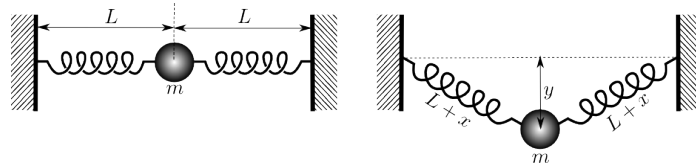
**Problem 34.** 1990-Fall-CM-U-2.jpg ID:CM-U-363

An artificial Earth satellite is initially orbiting the earth in a circular orbit of radius R_0 . At a certain instant, its rocket fires for a negligibly short period of time. This firing accelerates the satellite in the direction of motion and increases its velocity by a factor of α . The change of satellite mass due to the burning of fuel can be considered negligible.

1. Let E_0 and E denote the total energy of the satellite before and after the firing of the rocket. Find E solely in terms of E_0 and α .
2. For $\alpha > \alpha_{\text{es}}$ the satellite will escape from earth. What is α_{es} ?
3. For $\alpha < \alpha_{\text{es}}$ the orbit will be elliptical. For this case, find the maximum distance between the satellite and the center of the earth, R_{max} , in terms of R_0 and α .

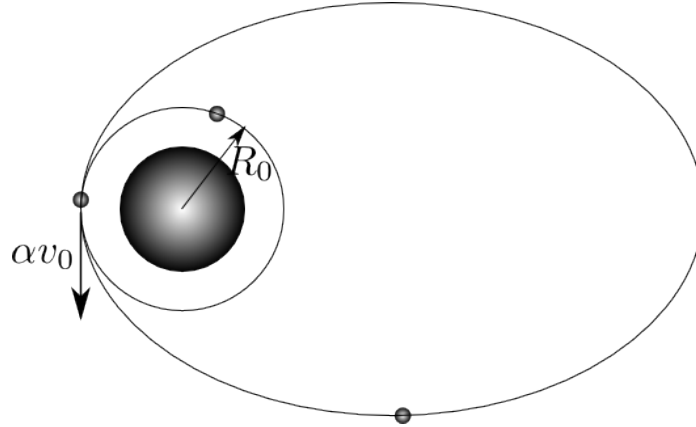

Problem 35. 1990-Fall-CM-U-3

ID:CM-U-377

A large sphere of radius R and mass M has a mass density that varies according to the distance from the center, r :

$$\rho(r) = \begin{cases} \rho_0 [1 - (r/R)^n], & \text{if } r \leq R; \\ 0, & \text{if } r > R. \end{cases}$$

where $n > 0$. A very small hole is drilled through the center of the sphere and a small object of mass m is released from rest into the hole at the surface. How fast will the object be moving when it reaches the center of the sphere? Express your answer through M , R , n , and G .

Problem 36. 1990-Spring-CM-U-1.

ID:CM-U-391

A particle of mass m and charge e is moving in an electric field \vec{E} and a magnetic field \vec{H} .

1. What is the general formula for the force acting on a charged particle by the fields? Write down the vector equation of motion for this charged particle in three dimensions.
2. Let $\vec{E} = 0$, and \vec{B} be uniform in space and constant in time. If the particle has an initial velocity which is perpendicular to the magnetic field, integrate the equation of motion in component form to show that the trajectory is a circle with radius $r = v/\omega$, where $\omega = eB/m$, (or eB/mc if you work in the Gaussian unit system).
3. Now suppose that $\vec{E} = (0, E_y, E_z)$, and $\vec{B} = (0, 0, B)$ are both uniform in space and constant in time, integrate the equation of motion in component form again, assuming that the particle starts at the origin with zero initial velocity.

Problem 37. *1990-Spring-CM-U-2.* ID:CM-U-401

A uniform rod, of mass m and length $2l$, is freely rotated at one end and is initially supported at the other end in a horizontal position. A particle of mass αm is placed on the rod at the midpoint. The coefficient of static friction between the particle and the rod is μ . If the support is suddenly removed:

1. Calculate by what factor the force on the hinge is instantaneously reduced?
2. The particle begins to slide when the falling rod makes an angle θ with the horizontal. Calculate this angle.

[Hint: To do this part, you need both components of the force equation on the mass αm ; plus the torque equation and the equation for the conservation of the energy of the whole system.]

Problem 38. *1990-Spring-CM-U-3.* ID:CM-U-411

For the masses in the figure, it is found that for one normal mode (“mode a”) the ratio of the displacements is $(x_2/x_1)_a = 3/2$. With $\omega_1^2 \equiv k/m_1$, and $\omega_2^2 \equiv k/m_2$, find ω_a^2/ω_1^2 , and ω_b^2/ω_1^2 for the second normal mode (“mode b”). Neglect the masses of the springs.

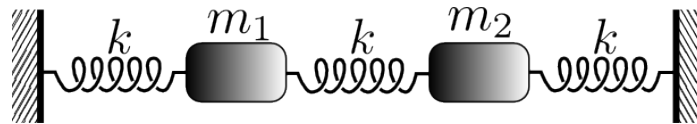
**Problem 39.** *1991-Fall-CM-U-1.* ID:CM-U-421

A large uniform density cube of mass M and side L is floating upright in a pond exactly half submerged. A small steel ball of mass $M/2$ is dropped directly over its center from the height H . Assume that the head-on collision is perfectly elastic and that the steel ball rebounds vertically,

1. Find the height the steel ball rebounds.
2. Find the depth to which the large cube descends.

Express your answers in terms of M , L , g , and H . Neglect all forms of dissipation and assume that the water surface remains level at all times.

Problem 40. *1991-Fall-CM-U-2.* ID:CM-U-431

A steel ball of mass M is attached by massless springs to four corners of a $2a$ by $b+c$ horizontal, rectangular frame. The springs constants k_1 and k_2 with corresponding equilibrium lengths $L_1 = \sqrt{a^2 + b^2}$ and $L_2 = \sqrt{a^2 + c^2}$ as shown. Neglecting the force of gravity,

1. Find the frequencies of small amplitude oscillations of the steel ball in the plane of rectangular frame.

- Identify the type of motion associated with each frequency.
- Is the oscillation of the steel ball perpendicular to the plane of the rectangular frame harmonic? Why or why not?

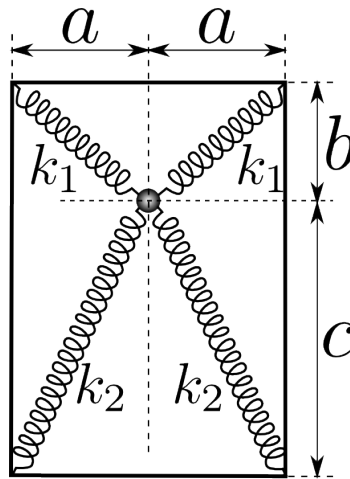

Problem 41. *A frame and a ball*

ID:CM-U-432

A ball of mass m is attached by massless springs to four corners of a a by b rectangular frame as shown on the figure. The springs' spring constants are k_1 and k_2 . The springs have negligible equilibrium (un-stretched) length. Neglect the force of gravity. The ball can move in all three directions.

- Find the equilibrium position of the ball.
- Find the frequencies of small amplitude oscillations of the ball around the equilibrium.
- Identify the type of motion associated with each frequency.

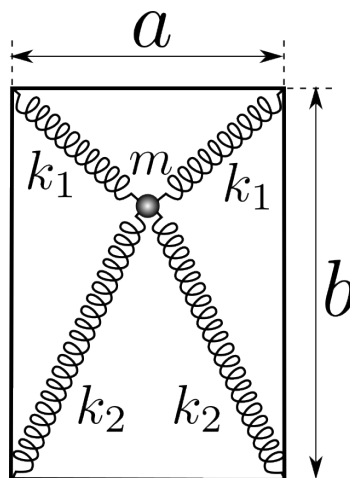

Problem 42. *1991-Fall-CM-U-3.* ID:CM-U-445

A small block of mass m is attached near the outer rim of a solid disk of radius a which also has mass m . The disk rolls without slipping on a horizontal straight line.

1. Find the equation of motion for the angle $\theta(t)$ (measured with respect to the vertical as shown) for all θ .
2. Find the system's small amplitude oscillation frequency about its stable equilibrium position.

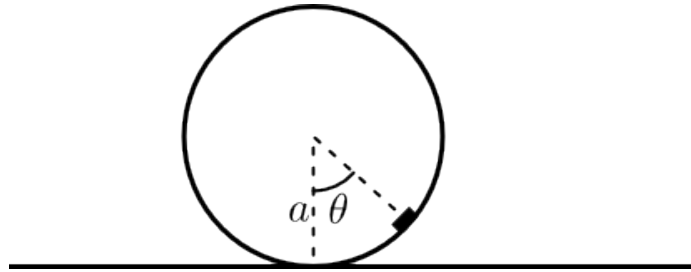
**Problem 43.** *1991-Spring-CM-U-1.* ID:CM-U-456

A baseball is thrown straight upward at a park in College Station. It has an initial speed of v_0 . The net force acting on the ball is given by

$$\mathbf{F} = -mg\mathbf{j} - k\mathbf{v},$$

where k is the air drag coefficient. (Note: the upward direction is taken to be \mathbf{j} .)

1. Find the magnitude of the velocity of the ball as a function of the time in terms of v_0 , g , m , and k .
2. Find t_{max} , the time required for the ball to reach its maximum height, in terms of v_0 , g , m , and k .
3. Find h_{max} , the maximum height reached by the ball above its point of release, in terms of v_0 , g , m , and k .

Problem 44. *1991-Spring-CM-U-2.* ID:CM-U-469

A circular platform of mass M and radius R is free to rotate about a vertical axis through its center. A man of mass M is originally standing right at the edge of the platform at the end of a line painted along a diameter of the platform. The platform and man are set spinning with an angular velocity ω_0 . At $t = 0$ the man begins to walk toward the center of the platform along the line so that his distance from the center is $R - v_0t$. If the man slips off the line when he is at $R/2$, what must be the coefficient of friction between the man and the platform?

Problem 45. 1991-Spring-CM-U-3.

ID:CM-U-473

A uniform sphere with a mass M and radius R is set into rotation with a horizontal angular velocity ω_0 . At $t = 0$, the sphere is placed without bouncing onto a horizontal surface as shown. There is friction between the sphere and the surface. Initially, the sphere slips, but after an unknown time T , it rolls without slipping.

1. What is the angular speed of rotation when the sphere finally rolls without slipping at time T ?
2. How much energy is lost by the sphere between $t = 0$ and $t = T$?
3. Show that amount of energy lost is equal to the work done against friction causing the sphere to roll without slipping?

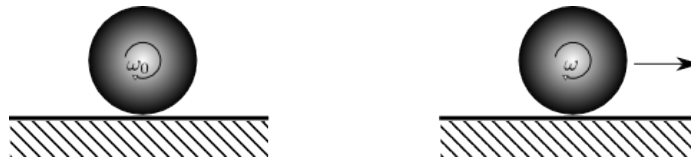

Problem 46. 1992-Fall-CM-U-1.

ID:CM-U-485

Two pendulums each of length l , whose motions are in the same plane, are initially situated as shown in the figure. The balls (labeled A and B) are made of the same material and have the same mass. In the collision of two balls, a coefficient e ($0 < e < 1$) is fixed, where e is defined as the ratio of the relative speeds between two balls after and before the collision $e = |v_{rel}(\text{after})|/|v_{rel}(\text{before})|$. Assume $\phi^{(0)}$ is small so that the frequency is independent of the amplitude (called “isochronism”) for each pendulum. The gravitational acceleration is g .

1. Obtain the speed of ball A , $v_A^{(0)}$, at the bottom just before the first collision.
2. Obtain the relative speed of two balls, $u^{(0)}$, at the bottom just after the first collision.
3. Find the maximum opening angle $\phi^{(n)}$ after the n -th collision.
4. If only ball A is set at $\phi = \phi^{(0)}$ initially, obtain the speed of each ball at the bottom after the n -th collision. What is the speed of each ball as $n \rightarrow \infty$?

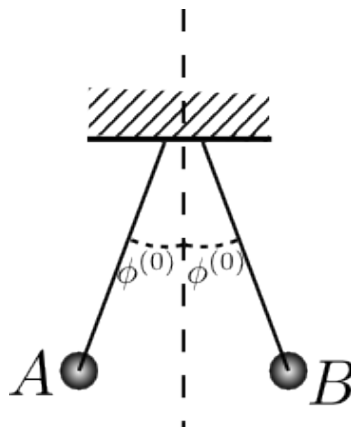

Problem 47. *1992-Fall-CM-U-2.* ID:CM-U-498

A toy consists of two equal masses (m) which hang from straight massless arms (length l) from a massless pin. The pin (length L) and the arms are in plane at angle α . Consider only motion in this plane.

1. Find the potential and kinetic energies of the masses as a function of θ , the angle between the vertical and the pin, and the time derivatives of θ . (Assume the toy is rocking back and forth about the pivot point.)
2. Find the condition in terms of L , l , and α such that this device is stable.
3. Find the period of oscillation if θ is restricted to very small values.

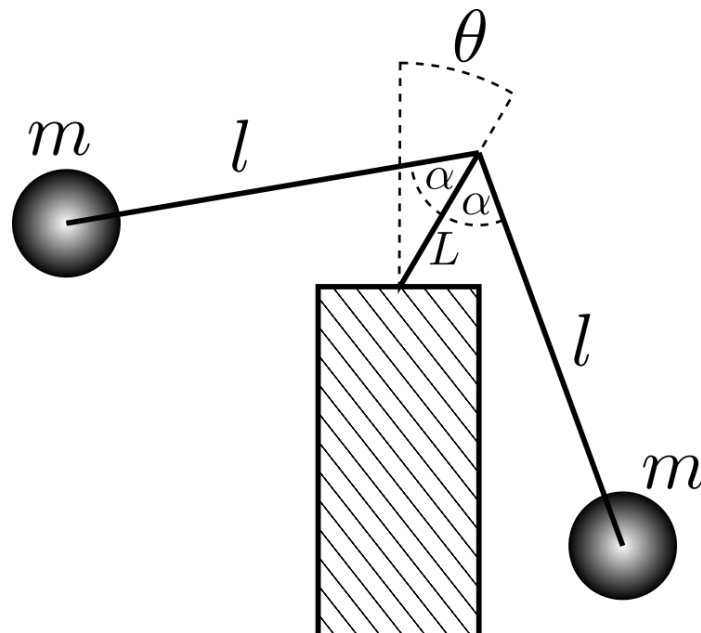
**Problem 48.** *1992-Fall-CM-U-3.* ID:CM-U-510

A homogeneous disk of radius R and mass M rolls without slipping on a horizontal surface and is attracted to a point Q which lies a distance d below the plane (see figure). If the force of attraction \vec{F} is proportional to the distance from the center of mass of the disk to the force center Q with the coefficient of proportionality k , so that $|\vec{F}| = kr$, find the frequency of oscillations about the position of equilibrium using the Lagrangian formulation.

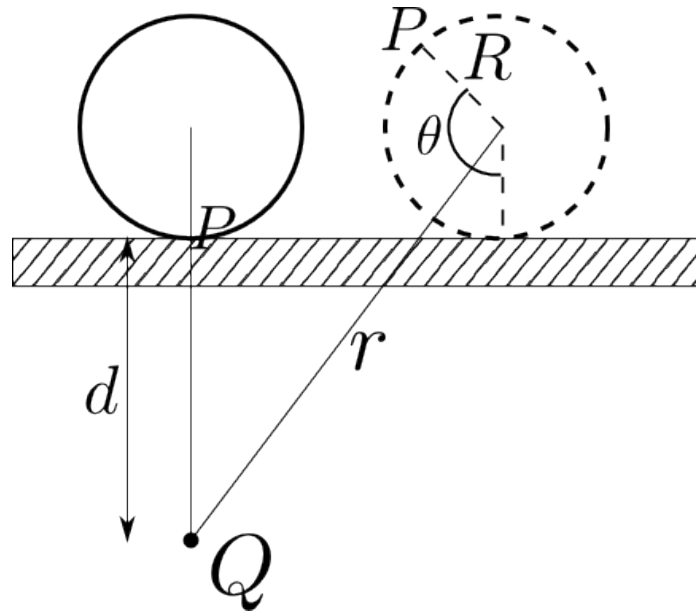

Problem 49. 1992-Spring-CM-U-1

ID:CM-U-517

For a particle of mass m subject to a central force $\mathbf{F} = \hat{\mathbf{r}}F_r(r)$, where $F_r(r)$ is an arbitrary function of the coordinate distance r from a fixed center:

1. Show that the energy E is a constant. What property of the force is used?
2. Show that the angular momentum \mathbf{L} is a constant. What property of the force is used?
3. Show that, as a consequence of the previous part, the motion of the particle is in a plane.
4. Show that, as a consequence, the trajectory of motion in polar coordinate can be solved by quadrature. (*i.e.*, the time-dependence of the coordinates can be expressed as integrals, which you should express, but which you cannot evaluate until the function $F_r(r)$ is specified.) For this part it will be useful to introduce an *effective potential* incorporating the angular momentum conservation.
5. Suppose $F_r(r)$ is attractive and proportional to r^n , where n is an integer. For what values of n are stable circular orbits possible?

[Hint: Use the effective potential defined before, make a rough drawing of the different possible situations, and argue qualitatively using this drawing.]

Problem 50. 1992-Spring-CM-U-3

ID:CM-U-538

News item: *In the basin of the river Podkamenaya Tunguska in central Siberia, a fearsome fireball came down from the heavens on June 30, 1908, at 7:17 A.M. local time. It was seen over a radius of 600 to 1000 kilometers; It scorched the vegetation for a radius of tens of kilometers. The air blast went around the earth. No meteoric fragments have ever been*

found; only some microscopic globules have been extracted from the soil and they are of uncertain connection with the event. The possibility that the explosion was caused by the arrival of a small bit of antimatter has been considered as a serious possibility.

Consider a small bit of antimatter coming straight down at high velocity. We want to make an approximate calculation to determine the initial mass it must have in order to just reach the surface of the earth. Assume the following simplified model of the event:

- The antimatter annihilates (converts to radiation) all the air in its path, cutting a clean hole through the atmosphere. Annihilation is mutual, a gram of matter for every gram of antimatter.
- The arriving bit of antimatter is a spherical piece of anti-iron that stays spherical as it decreases in size while passing through the atmosphere.
- Assume the density ρ of the earth's atmosphere is a linear function of height x above the surface for $0 \leq x \leq 16000\text{m}$; and that $\rho = 0$ for $x \geq 16000\text{m}$.

Define the following parameters:

- ρ_0 is the density of the earth's atmosphere at the surface of the earth.
- $r(x)$ is the radius of the sphere of antimatter at height x above the surface.
- R is the initial radius of the sphere of antimatter, $R = r(x \geq 16000\text{m})$.
- ρ_a is the density of the antimatter, $\rho_a \approx 8\text{gm/cm}^3$.
- $M_a(x)$ is the mass of the antimatter at a height x . Note, $M_a(0) = 0$.
- $M_m(x)$ is the mass of air that has been annihilated when the antimatter has reached a height x above the surface. Note, $M_m(0) = M_a(\infty)$.

Questions:

1. Using this linear model of the atmosphere together with the fact that atmospheric pressure at the surface of the earth is $\approx 10^5\text{N/m}^2$, determine ρ_0 .
2. Write (i) $M_a(x)$ in terms of ρ_a and $r(x)$, (ii) an expression for $M_a(x)$ in terms of R and $M_m(x)$, (iii) an explicit integral expression for $M_m(x)$.
3. Determine $r(x)$. You may find it helpful to first determine dr/dx and then integrate.
4. Evaluate R and $M_a(\infty)$ numerically.
5. TNT releases about 1000 calories per gram. Determine the megaton equivalent of this piece of antimatter. Note: 1pound= 454grams; 1ton= 2000pounds.

Problem 51. 1993-Fall-CM-U-1 ID:CM-U-583

A satellite of mass m is traveling at speed v_0 in a circular orbit of radius r_0 under the gravitational force of a fixed mass M at point O . At a certain point Q in the orbit (see the figure below) the direction of motion of the satellite is suddenly changed by an angle α without any change in the magnitude of the velocity. As a result the satellite goes into an elliptic orbit. Its distance of the closest approach to O (at point P) is $r_0/5$.

1. What is the speed of the satellite at P , expressed as a multiple of v_0 ?
2. Find the angle α .

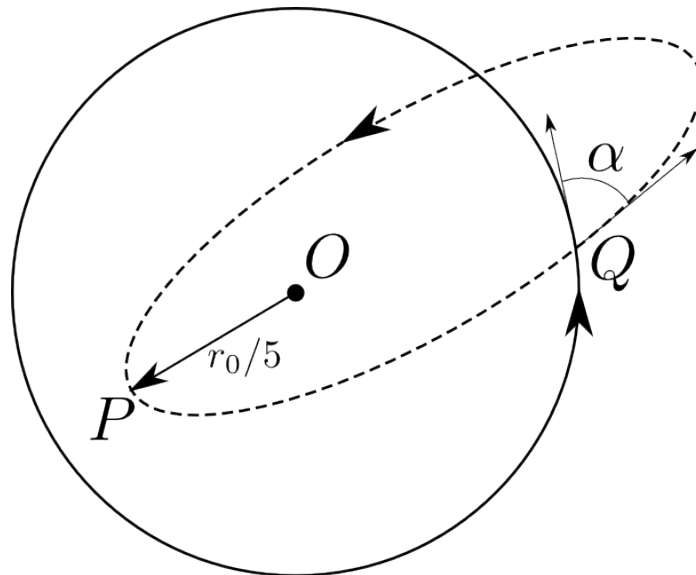
**Problem 52.** 1993-Fall-CM-U-2. ID:CM-U-599

A “Yo-Yo” (inner and outer radii r and R) has mass M and moment of inertia about its symmetry axis Mk^2 .

1. The Yo-Yo is attached to a wall by a massless string and located on the slope as shown in Fig. a). The coefficient of static friction between the slope and Yo-Yo is μ . Find the largest angle θ before the Yo-Yo starts moving down.
2. Now, consider Yo-Yo which is falling down as shown in Fig. b). Find the ratio of its translational and rotational kinetic energies.

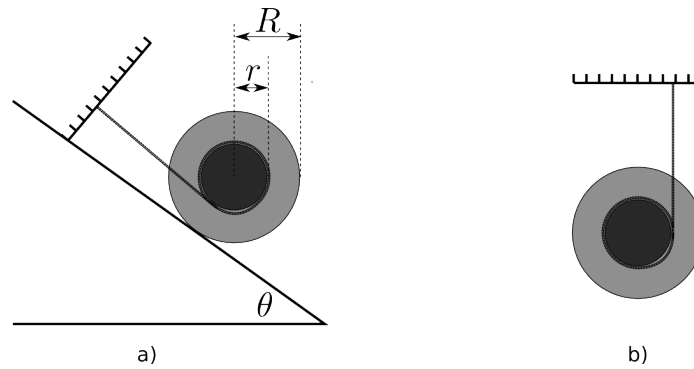

Problem 53. 1993-Fall-CM-U-3.

ID:CM-U-612

A point-like test mass m is placed at the center of a spherical planet of uniform density, mass M and radius R .

1. Calculate the energy required to remove this test mass to an infinite distance from the planet.
2. Calculate the gravitational binding energy of this planet (without the test mass), i.e. the energy required to break the planet up into infinitesimal pieces separated by an infinite distance from each other.

Problem 54. 1993-Fall-CM-U-4

ID:CM-U-620

A block of mass m is located at the top of a wedge, as shown in the figure. The wedge is fixed to a bus moving at a constant speed of u to the right. The block is released at $t = 0$ and slides down the wedge. The friction is negligible. A student calculates the speed of the block at the bottom of the wedge in the “moving bus frame” by conservation of energy:

$$\frac{mv^2}{2} = mgH$$

Therefore, $v = \sqrt{2gH}$.

The student, now working in the “ground frame”, again uses conservation of energy:

$$\frac{mw^2}{2} = \frac{mu^2}{2} + mgH$$

where w is the speed of the block at the bottom of the wedge in the ground frame. Therefore,

$$w = \sqrt{2gH + u^2}. \quad \text{— result (1)}$$

He now checks to see if this result agrees with the one he expected from $\vec{w} = \vec{v} + \vec{u}$:

$$w = \sqrt{(\vec{v} + \vec{u})^2} = \sqrt{v^2 + u^2 - 2vu \cos \theta} = \sqrt{2gH + u^2 - 2vu \cos \theta} \quad \text{— result (2)}$$

He finds two different results (1) and (2). Determine which result is wrong, (1), (2) or both, and correct the error(s) in the above derivation(s).

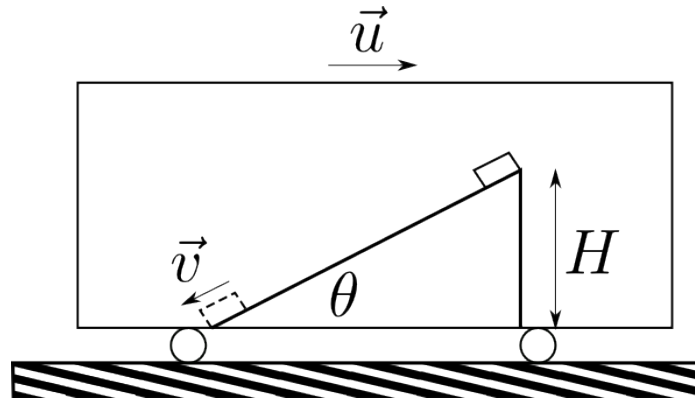

Problem 55. 1993-Spring-CM-U-2

ID:CM-U-650

A sailboat is at rest because there is no wind. The boat is located at the equator. The captain decides to raise the anchor from the deck to the top of the mast which is H high. The mass of the anchor is m and the rest of the boat has a mass of M . Ignore any frictional forces exerted by the water on the boat. Call the radius of the earth R .

1. The boat begins to move. Why?
2. Which direction does it move?
3. What is the boat's surface speed when the anchor is at the top?
4. Where does the energy come from?

Problem 56. 1993-Spring-CM-U-3

ID:CM-U-667

A thin flat uniform square plate of side l and mass m is supported vertically at the corners by 4 vertical springs 1,2,3,4 which have spring constants $k_1 = k_3 = K$, $k_2 = k_4 = 2K$. Assume constraints that eliminate horizontal translation but allow small rotations about the center of mass of the plate.

Find the three eigen-frequencies and their relative amplitudes. Describe these modes.

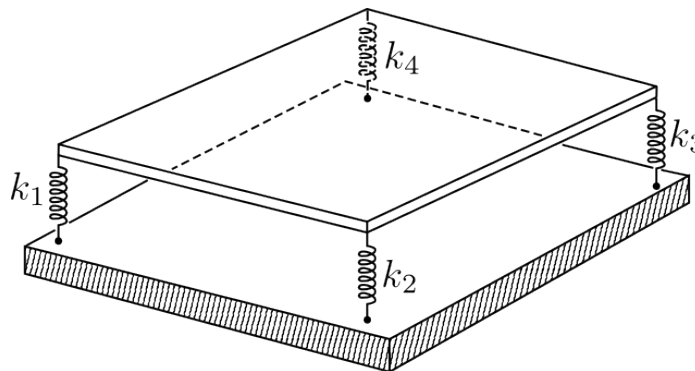

Problem 57. *1994-Fall-CM-U-1* ID:CM-U-679

Two uniform very long (infinite) rods with identical linear mass density ρ do not intersect. Their directions form an angle α and their shortest separation is a .

1. Find the force of attraction between them due to Newton's law of gravity.
2. Give a dimensional argument to explain why the force is independent of a .

Note: for $A^2 < 1$, $\int_{-\pi/2}^{\pi/2} \frac{d\theta}{1-A^2 \sin^2 \theta} = \frac{\pi}{\sqrt{1-A^2}}$

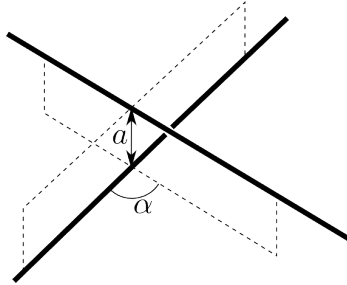
**Problem 58.** *1994-Fall-CM-U-2* ID:CM-U-697

Suppose that the payload (e.g., a space capsule) has mass m and is mounted on a two-stage rocket (see figure below). The total mass — both rockets fully fueled, plus the payload — is Nm . The mass of the second-stage plus the payload, after first-stage burnout and separation, is nm . In each stage the ratio of burnout mass (casing) to initial mass (casing plus fuel) is r , and the exhaust speed is v_0 .

1. Find the velocity v_1 gained from first-stage burn starting from rest (and ignoring gravity). Express your answer in terms of v_0 , N , n , and r .
2. Obtain a corresponding expression for the additional velocity, v_2 gained from the second-stage burn.
3. Adding v_1 and v_2 , you have the payload velocity v in terms of N , n , v_0 , and r . Taking N , v_0 , and r as constants, find the value for n for which v is a maximum.
4. Show that the condition for v to be a maximum corresponds to having equal gains of velocity in the two stages. Find the maximum value of v , and verify that it makes sense for the limiting cases described by $r = 0$ and $r = 1$.
5. You need to build a system to obtain a payload velocity of 10km/sec, using rockets for which $v_0 = 2.5\text{km/sec}$ and $r = 0.1$. Can you do it with a two-stage rocket?
6. Find an expression for the payload velocity of a single-stage rocket with the same values of r and v_0 . Can you reach a payload velocity of 10km/s with a single-stage rocket by taking the same conditions as in the previous point?

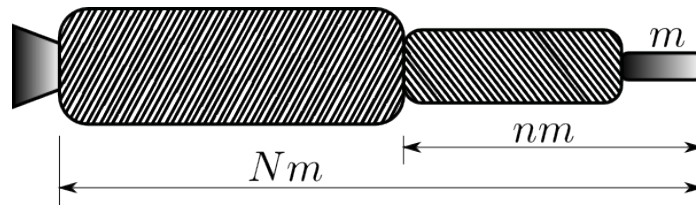

Problem 59. 1994-Fall-CM-U-3

ID:CM-U-720

A particle of mass m moving parallel to the y -axis with a velocity v and impact parameters x and z is incident upon a uniform ellipsoid of revolution of mass M with semi-axes $a = b$ and c , as shown in the figure (Note: $\frac{x^2}{a^2} + \frac{z^2}{c^2} < 1$). The particle sticks to the surface of the ellipsoid as it strikes it. Describe quantitatively the motion of the ellipsoid as function of time assuming its mass to be much larger than that of the particle. Note: Moment of inertia of the ellipsoid around c axis is $\frac{2}{5}Ma^2$ and around the a axis it is $\frac{1}{5}M(a^2 + c^2)$.

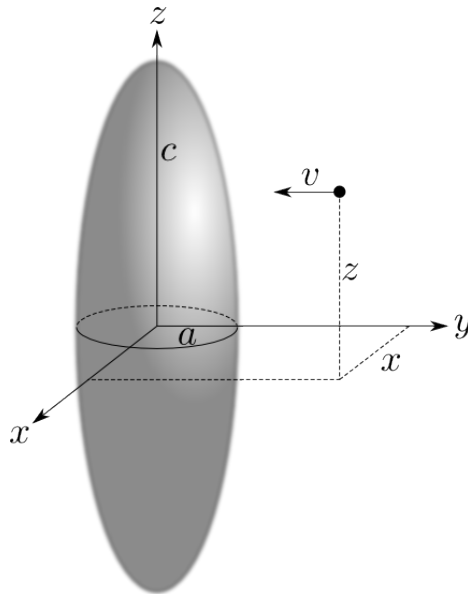

Problem 60. 1994-Fall-CM-U-4

ID:CM-U-730

The most efficient way to transfer a spacecraft from an initial circular orbit at R_1 to a larger circular orbit at R_2 is to insert it into an intermediate elliptical orbit with radius R_1 at perigee and R_2 at apogee. The following equation relates the semi-major axis a , the total energy of the system E and the potential energy $U(r) = -GMm/r \equiv -k/r$ for an elliptical orbit of the spacecraft of mass m about the earth of mass M :

$$R_1 + R_2 = 2a = \frac{k}{|E|}.$$

1. Derive the relation between the velocity v and the radius R for a circular orbit.
2. Determine the velocity increase required to inject the spacecraft into the elliptical orbit as specified by R_1 and R_2 . Let v_1 be the velocity in the initial circular orbit and v_p be the velocity at perigee after the first boost so $\Delta v = v_p - v_1$.

- Determine the velocity increment required to insert the spacecraft into the second circular orbit when it reaches apogee at $r = R_2$. In this case let v_2 be the velocity in the final orbit and v_a be the velocity at apogee so $\Delta v = v_2 - v_a$.

Problem 61. 1994-Spring-CM-U-1

ID:CM-U-749

A bullet of mass m_1 , is fired with velocity v_0 at a solid cube of side a on the frictionless table. The cube has mass of m_2 and supports a pendulum of mass m_3 and length l . The cube and pendulum are initially at rest. The bullet becomes embedded in the center of the cube instantaneously after the collision.

- If θ_{max} is the maximum angle through which the pendulum swings, find the velocity v_0 of the incident bullet.
- When the pendulum's swing reaches the maximum angle, the pendulum's string is cut off. Therefore the solid cube slides and hits a small obstacle which stops the leading edge of the cube, forcing it to begin rotating about the edge. Find the minimum value of v_0 such that the cube will flip over. Note that the moment of inertia of the cube about an axis along one of its edge is $\frac{2}{3}Ma^2$. Assume the bullet is a point located at the center of the cube.

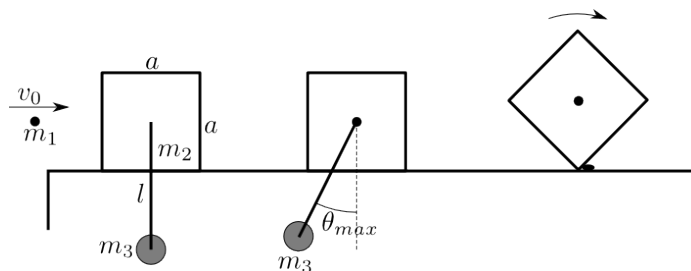
**Problem 62.** 1994-Spring-CM-U-2

ID:CM-U-765

A particle of mass m moves in one dimension under the influence of a harmonic force $F(x) = -kx$, ($k > 0$) according to $x(t) = A \cos \omega_0 t$, ($\omega_0 = \sqrt{k/m}$). The presence of the additional small anharmonic force $-\beta x^3$, ($\beta > 0$) leads to a change in the oscillatory frequency compared to the $\beta = 0$ case and also causes higher harmonics to appear in the expression for $x(t)$.

- Considering $x(t)$ as a Fourier series in ωt find the leading order corrections to ω and $x(t)$ due to the anharmonic term. Assume $|\beta x^2| \ll k$.
- Apply your result from the previous part to the simple pendulum to find the leading order finite amplitude correction to the small-amplitude period.

Problem 63. 1994-Spring-CM-U-3 ID:CM-U-778

A wire has the shape of a hyperbola, $y = c/x$, $c > 0$. A small bead of mass m can slide without friction on the wire. The bead starts at rest from a height h as shown in the figure

1. Find the velocity vector \vec{v} of the bead as a function of x .
2. Find the force \vec{F} that the bead exerts on the wire as a function of x .

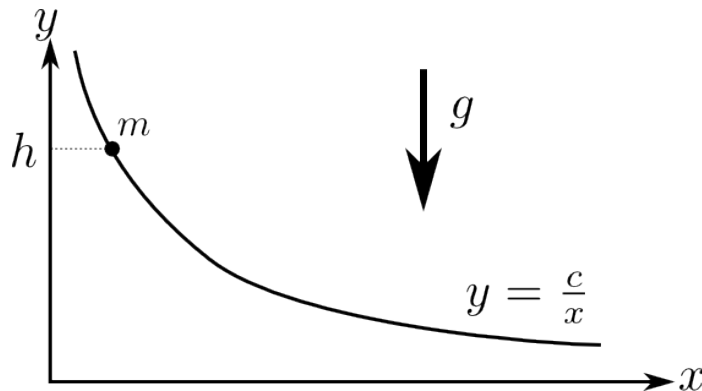
**Problem 64.** 1994-Spring-CM-U-4 ID:CM-U-793

A person wants to hold up a large object of mass M by exerting a force F on a massless rope. The rope is wrapped around a fixed pole of radius R . The coefficient of friction between the rope and the pole is μ . If the rope makes $n + 1/2$ turns around the pole, what is the maximum weight the person can support?

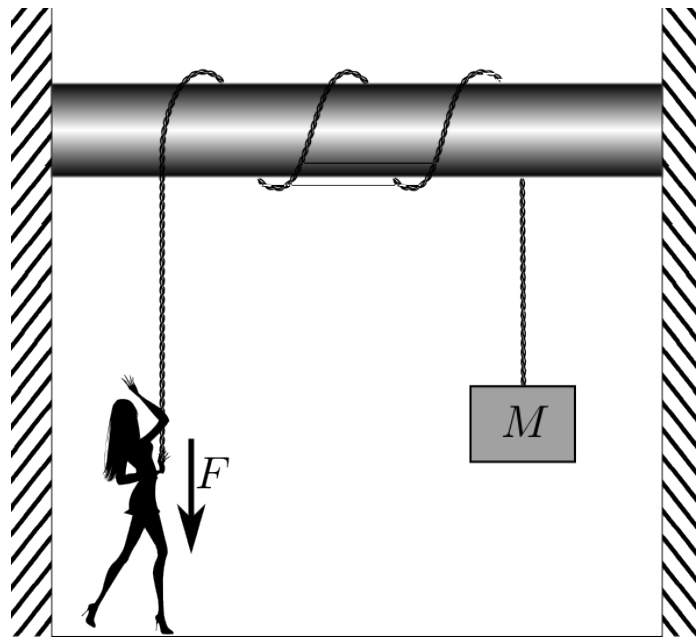

Problem 65. 1995-Fall-CM-U-1

ID:CM-U-802

An open water tank is to be built with a hole of area A_0 in the bottom so that the height of the water will decrease at a constant rate c . The tank can then be used as a clock. Assume water to be ideal (incompressible, without viscosity) and assume that the atmospheric pressure difference between the bottom and the top of the tank can be neglected.

1. What shape should the tank have? Is the solution unique?
2. Assuming the tank to have circular symmetry around a vertical axis, as shown in the figure, determine its shape $y(x)$.
3. Given the instantaneous water level y_1 , find the height h at which the pressure inside the tank is maximal at that instant.

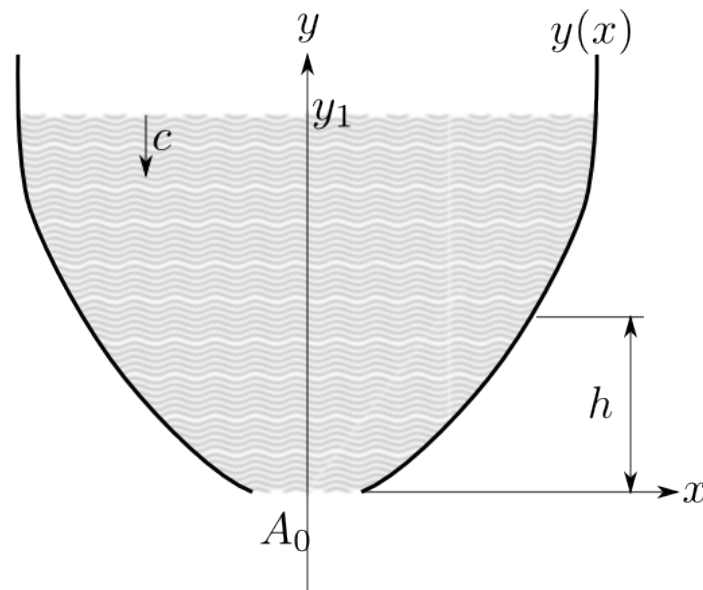
**Problem 66.** 1995-Fall-CM-U-2

ID:CM-U-819

A boat of mass m_0 is initially propelled at constant speed v_0 by a force F through water which offers a resistance $f = kv$, where k is a constant and v is the velocity of the boat. Then at time $t_0 = 0$ the boat springs a leak and subsequently takes in water at a constant rate λ (mass/time). The boat sinks when the mass of water taken in is also m_0 . Find the distance that the boat travels before sinking after springing the leak. Assume that the propelling force F and the resistive constant k do not change after the boat has taken in water.

Problem 67. 1995-Fall-CM-U-3

ID:CM-U-826

A uniform solid cylinder of mass M and radius R is held with its symmetry axis horizontal, just above a flat horizontal surface. The cylinder is given an initial angular velocity ω_0 about its symmetry axis and then is dropped. Initially, after impact with the surface, the cylinder slips as it begins to translate. After a time t , pure rolling

motion begins. The coefficient of kinetic friction between the cylinder and the surface is μ .

1. Determine the equation for the time t .
2. Determine the equation for the velocity of the center of mass when rolling begins.

Problem 68. *1995-Spring-CM-U-1.*

ID:CM-U-838

Masses m_a and m_b and three unstretched springs just span the distance between two supports, as illustrated in the figure. The two outer springs are identical and have spring constants k , and the middle spring has spring constant K . The masses are constrained to move along the straight horizontal line connecting the two supports.

1. Write down the equations of motion of masses m_a and m_b , denoting their displacement x_a and x_b from their equilibrium positions.
2. Determine the two characteristic frequencies of the system for arbitrary m_a and m_b .
3. Determine the two normal modes associated with the two frequencies when $m_a = m_b$.



Problem 69. *1995-Spring-CM-U-2.*

ID:CM-U-852

A uniform cylinder of mass m and radius R is to roll, without slipping, down an inclined plane. If the coefficient of (static) friction between the cylinder and the plane is μ , then to what highest angle θ can the plane be elevated if the cylinder is not to slip?

Problem 70. *1995-Spring-CM-U-3*

ID:CM-U-856

A uniform line-like bar of mass M , and length $2l$ rests on a frictionless, horizontal table. A point-like particle of mass $m \ll M$ slides along the table with velocity v_0 perpendicular to the bar and strikes the bar very near one end, as illustrated below. Assume that the force between the bar and the particle during the collision is in the plane of the table and perpendicular to the bar. If the interaction is elastic (*i.e.*, if energy is conserved) and lasts an infinitesimal amount of time, then determine the rod's center-of-mass velocity V and angular velocity ω , and the particle's velocity v after the collision.

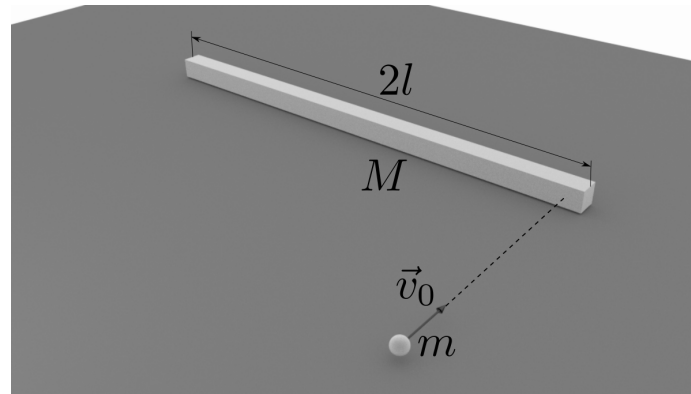

Problem 71. 1996-Fall-CM-U-1

ID:CM-U-865

Two pucks, each of mass m , are connected by a massless string of length $2L$ as illustrated below. The pucks lie on a horizontal, frictionless sheet of ice. The string is initially straight (*i.e.*, $\theta = 90^\circ$). A constant, horizontal force F is applied to the middle of the string in a direction perpendicular to the line joining the pucks. When the pucks collide, they stick together. How much mechanical energy is lost in the collision?

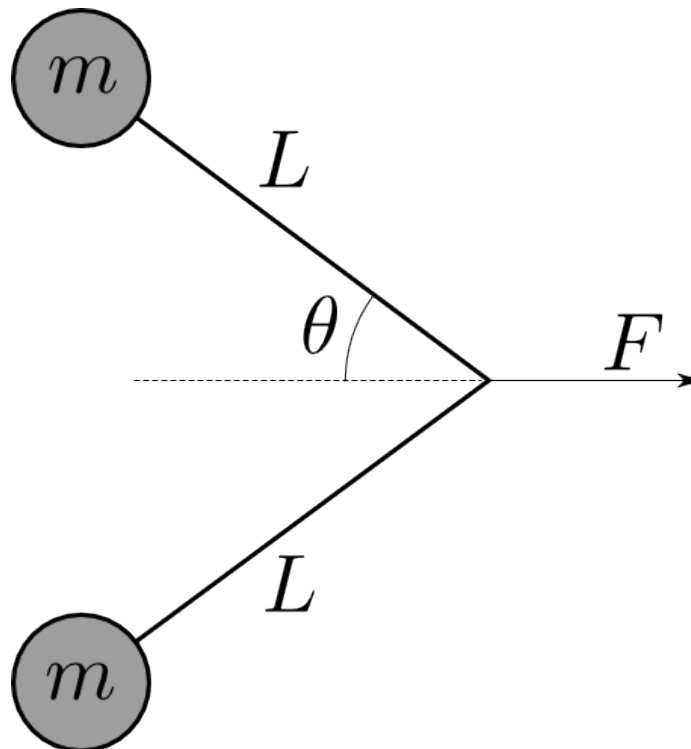

Problem 72. 1996-Fall-CM-U-2

ID:CM-U-875

A particle of mass m slides down a curve $y = kx^2$, ($k > 0$) under the influence of gravity, as illustrated. There is no friction, and the particle is constrained to stay on the curve. It starts from the top with negligible velocity.

1. Find the velocity (vector!) \vec{v} as a function of x . (use the system of coordinates shown in the figure.)
2. Next, assume that the particle initially slides down the curve under gravity, but this time it is only supported (but not constrained) by the curve. Does it leave the curve after it has slid a certain distance? Prove your answer.

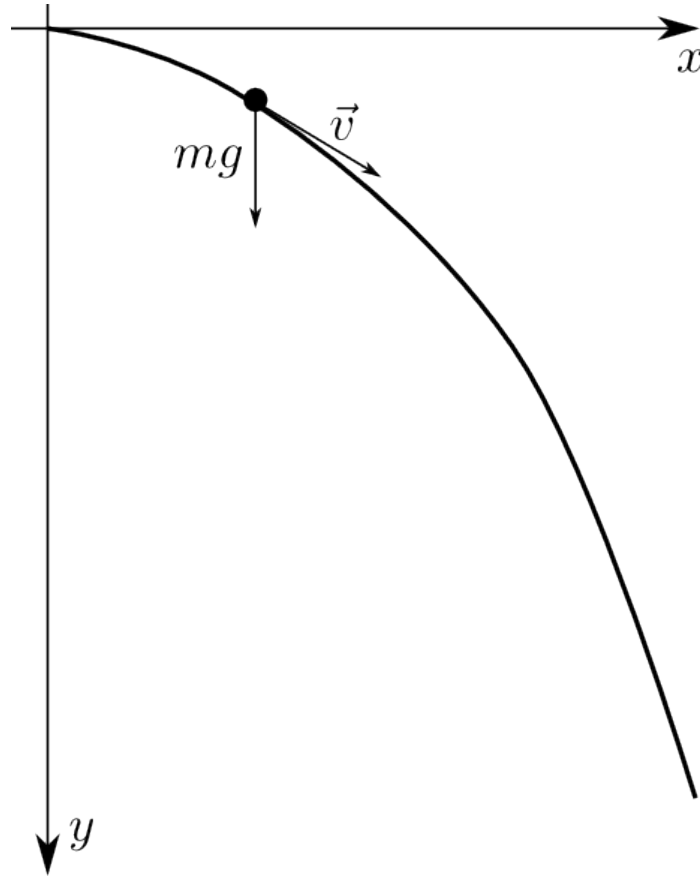

Problem 73. 1996-Fall-CM-U-3

ID:CM-U-896

A rod of mass M and length L rotates freely about a vertical axle through its center, as illustrated. A bug of mass m stands at the center of the rod. The system is set into rotation about the axle with initial angular velocity ω_0 . The bug then begins to walk toward the end of the rod so that its distance from the center is bt^2 , where b is a constant.

1. Find both components of the force exerted on the bug as a function of time.
2. Find the angular velocity of the system when the bug just arrives at the end of the rod, and the angle that the rod turns through while the bug walks from the center to the end of the rod.

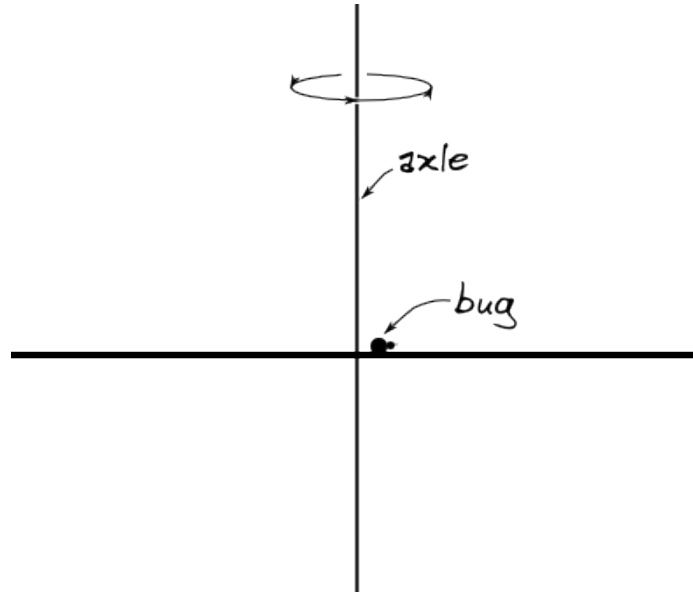

Problem 74. 1996-Spring-CM-U-1

ID:CM-U-917

A billiard ball initially at rest, is given a sharp impulse by a cue stick. The cue stick is held horizontally a distance h above the centerline as in the figure below. The ball leaves the cue with a horizontal speed v_0 and, due to its spin, eventually reaches a final speed of $9v_0/7$. Find h in terms of R , where R is the radius of the ball. You may assume that the impulsive force F is much larger than the frictional force during the short time that the impulse is acting.

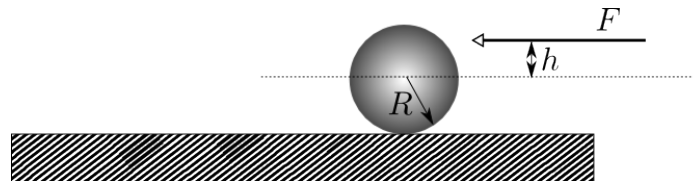

Problem 75. 1996-Spring-CM-U-2

ID:CM-U-928

A thin sheet of material of uniform thickness and uniform density has a horizontal dimension L meters and a vertical dimension H meters. Its total mass is M kilograms.

1. Calculate the moment of inertia of this rectangular body about an axis through the center of mass parallel to a side of dimension L . (Your answer should be given in terms of any of the required descriptive parameters given above but should especially include the mass M .)
2. Suppose the rectangle described above is placed with one side of length L along the horizontal z -axis of a right-handed coordinate system shown below (The z -axis is pointing out of the plane of the paper.) The rectangle is supported on a frictionless horizontal surface coincident everywhere with the $x - z$ plane and is initially at rest with its plane at angle θ with respect to the horizontal as shown below. Note that the gravitational force acts along the vertical y -axis.

Assume the rectangle is released from rest at the initial position described immediately above. Calculate the velocity of the center of mass of the rectangle just before it strikes the horizontal plane.

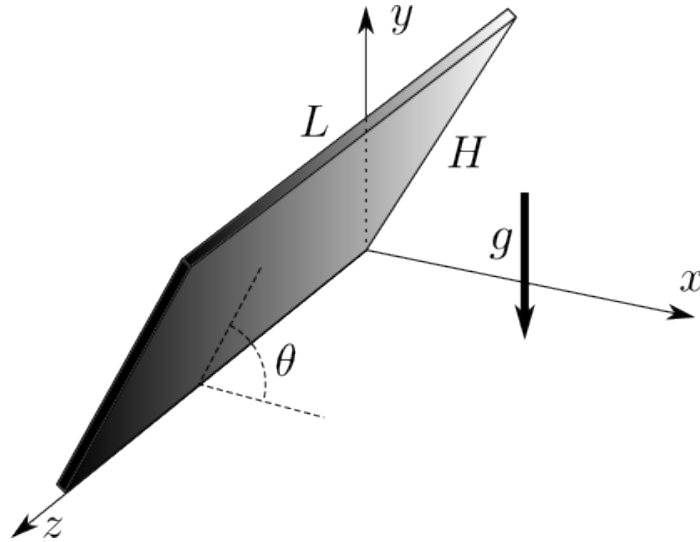

Problem 76. 1997-Fall-CM-U-1

ID:CM-U-951

Gravity g and a drag force

$$F_d = F_0 \frac{\dot{y}/v_0}{1 + (\dot{y}/v_0)^2}$$

act on a mass m constrained to move vertically. Take the downward direction to be positive y .

1. Sketch F_d vs. \dot{y} . Indicate where F_d reaches its maximum value and give \dot{y} at $(F_d)_{max}$.
2. If at $t = 0$ the mass is at rest at $y = 0$ and if $\dot{y} \ll v_0$ for all time t , then find y as a function of t .
3. What condition must be satisfied so that $\dot{y} \ll v_0$ for all time t ?

For the remaining parts, assume that $F_0 = 4mg$ and take the drag force into account exactly.

4. What limiting values of \dot{y} can occur? Denote these \dot{y}_1 , and \dot{y}_2 , with $|\dot{y}_1| < |\dot{y}_2|$. Do not try to solve the remaining parts analytically.
5. If \dot{y} differs slightly from \dot{y}_1 , then describe the subsequent motion of the particle.
6. If \dot{y} is slightly less than \dot{y}_2 , then describe the subsequent motion of the particle.
7. If \dot{y} is slightly greater than \dot{y}_2 , then describe the subsequent motion of the particle.

Problem 77. *1997-Fall-CM-U-2* ID:CM-U-992

A point particle of mass m is constrained to move on a hyperbolic spiral and in a central force field characterized by the potential

$$V = -kr^{-n},$$

where k is a positive constant. The spiral is described by the equation

$$r\theta = r_0,$$

where r_0 is a positive constant.

1. Construct the Lagrangian of the system.
2. Calculate the ratio F_r/F_θ of the constraint forces F_r , and F_θ as a function of r for arbitrary n .
3. Under certain conditions F_r , and F_θ vanish. Derive the critical value of n , and the relation among k , m , r_0 , and the initial radial speed v_0 . such that this occurs.

Problem 78. *1997-Fall-CM-U-3* ID:CM-U-1015

Under the influence of gravity, a sphere of mass m , radius R and moment-of-inertia I rolls downward without slipping on a wedge of triangular cross section and mass M . The wedge slides without friction on a horizontal plane. This is illustrated below. At $t = 0$, let $X = 0$ and $s = 0$.

1. Write down the Lagrangian for the system.
2. Find the horizontal and vertical components of the acceleration of the wedge and the sphere.
3. If $M = 0$ and $I = 0$ (the sphere's mass m concentrated at its center), then what are the accelerations of the sphere and the wedge? Give the magnitude and direction of each.

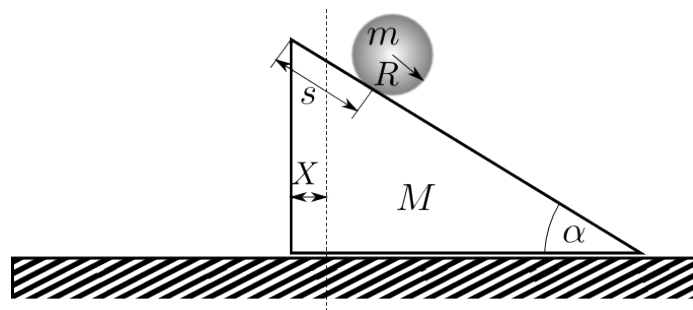

Problem 79. *1997-Spring-CM-U-1* ID:CM-U-1032

Two sticks, each of length l and mass M , are joined together at a right angle to form a "T-square". This T-square is then hung on a nail, on which it is free to rotate about O , as shown. Find

1. its moment of inertia I about O ;
2. the torque due to gravity about O when its bisector is at angle θ , as shown;
3. its period of small oscillations.

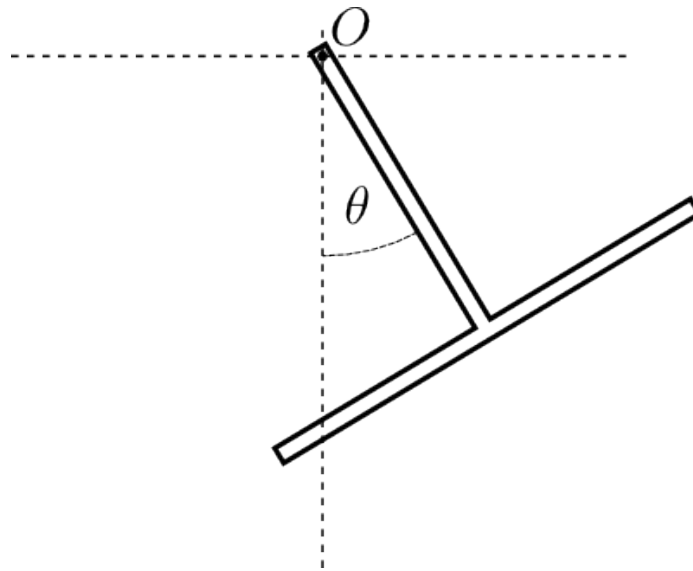
**Problem 80.** *1997-Spring-CM-U-2* ID:CM-U-1049

A particle of mass m moves in a region where its potential energy is given by

$$V = Cr^4,$$

where C is a real, positive constant. Consider the case where the particle moves in a circular orbit of radius R .

1. Express its total energy E and angular momentum L as a function of R .
2. Determine the period τ_{orb} , of this circular orbit as a function of R .
3. What is its period τ_{rad} for small radial oscillations if the orbit is slightly perturbed? Express τ_{rad} as a factor times τ_{orb} .

Problem 81. *1997-Spring-CM-U-3* ID:CM-U-1067

A particle of mass m is moving under the influence of a force given by

$$\vec{F} = \lambda \vec{r} \times \dot{\vec{r}},$$

where λ is a constant.

1. Show that the speed of the particle is constant, i. e., $\vec{v} \cdot \vec{v} = \text{const.}$
2. Show that the radial component of the acceleration is zero.
3. Using the results of parts of the two previous parts, show that the distance of the particle from the origin is given by

$$r = \sqrt{c_0 + c_1 t + c_2 t^2},$$

where c_0 , c_1 , and c_2 are integration constants.

4. Show whether or not angular momentum is conserved.

Useful formulas components of \vec{r} , $\dot{\vec{r}} \equiv \vec{v}$, and $\ddot{\vec{r}} \equiv \vec{a}$ in spherical coordinates:

$$\vec{r} = r \hat{e}_r$$

$$\vec{v} = \dot{r} \hat{e}_r + r \dot{\theta} \hat{e}_\theta + r(\sin \theta) \dot{\phi} \hat{e}_\phi$$

$$\vec{a} = \left[\ddot{r} - r \dot{\theta}^2 - r(\sin \theta)^2 \dot{\phi}^2 \right] \hat{e}_r + \left[r \ddot{\theta} + 2 \dot{r} \dot{\theta} - r(\sin \theta) \dot{\phi}^2 \right] \hat{e}_\theta + \left[r(\sin \theta) \ddot{\phi} + 2(\sin \theta) \dot{r} \dot{\phi} + r(\cos \theta) \dot{\theta} \dot{\phi} \right] \hat{e}_\phi$$

where

$$\hat{e}_r \cdot \hat{e}_r = 1, \quad \hat{e}_\theta \cdot \hat{e}_\theta = 1, \quad \hat{e}_\phi \cdot \hat{e}_\phi = 1, \quad \hat{e}_r \cdot \hat{e}_\theta = 0, \quad \hat{e}_r \cdot \hat{e}_\phi = 0, \quad \hat{e}_\theta \cdot \hat{e}_\phi = 0,$$

Vector products:

$$\vec{A} \cdot [\vec{B} \times \vec{C}] = \vec{B} \cdot [\vec{C} \times \vec{A}] = \vec{C} \cdot [\vec{A} \times \vec{B}], \quad \vec{A} \times [\vec{B} \times \vec{C}] = \vec{B} (\vec{A} \cdot \vec{C}) - \vec{C} (\vec{A} \cdot \vec{B})$$

Problem 82. *1998-Fall-CM-U-1* ID:CM-U-1121

A particle of mass m is acted upon by a force $F_x = -k_1 x$, $F_y = -k_2 y$, $F_z = 0$.

1. Suppose the initial velocity in the z direction is zero. Show that the motion must be in a plane perpendicular to the z axis.
2. Show analytically that the force on the mass is non-central unless $k_1 = k_2$.
3. Using x and y as your “generalized coordinates” set up the Lagrange equations and demonstrate that these lead to the equations of motion of the two-dimensional harmonic oscillator.
4. Find the orbit of the mass in parametric form.

5. Show that the time rate of change of the angular momentum of the mass about the z axis is proportional to the difference $k_1 - k_2$.
6. Determine the ratios of k_1/k_2 which cause the motion of the mass to be periodic.

Problem 83. *1998-Fall-CM-U-3*

ID:CM-U-1146

The two "blocks" in the figure below are frictionless and have the same mass m . The larger block is sitting on a horizontal, frictionless table. The three springs are massless and have the same spring constant k . When one of the springs connecting the two blocks together is at its natural length, the other one is also at its natural length.

1. Draw a figure which clearly shows your choice of generalized coordinates. For each generalized coordinate, determine the associated generalized momentum. Give interpretations of your generalized momenta in terms of simple physical concepts.
2. Find the Hamiltonian equations of motion of the system.
3. Determine the frequencies of the normal modes of oscillation of this system.

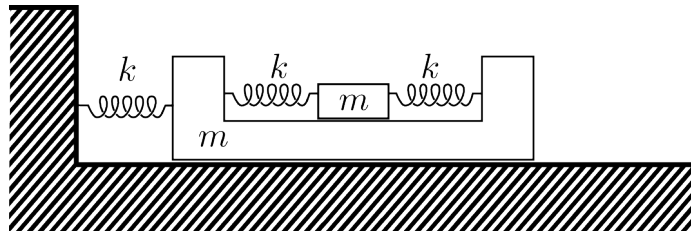
**Problem 84.** *1998-Spring-CM-U-1*

ID:CM-U-1166

The system shown below consists of two small beads, one of mass m and the other of mass $2m$, that are both free to slide on the horizontal frictionless fixed ring of radius R . The beads are connected by springs, one with spring constant k and the other with spring constant $2k$, that wind around the ring as shown. The equilibrium length of each of the springs is πR .

1. Find equations of motion for the two beads. Be sure to draw a figure that clearly defines your choice of generalized coordinates.
2. Find the frequencies of small oscillation of the system and the normal mode associated with each of the small oscillation frequencies.
3. Give a simple physical interpretation of the frequencies and normal modes that you found in the previous part.

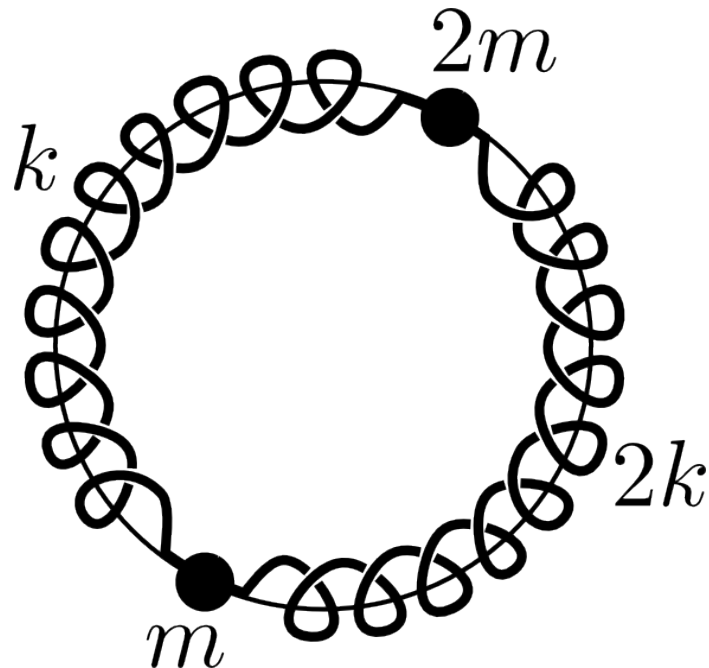

Problem 85. 1998-Spring-CM-U-2

ID:CM-U-1186

A flat pie shaped wedge cut from a disc lies in the XOY plane. The disc has radius a . The angle of the wedge is 2θ . The density of the disc is $\rho = \rho_0 r = \rho_0 \sqrt{x^2 + y^2}$, where r is the distance of the point (x, y) from O .

1. Find the moment of inertia of the wedge about the z -axis.
2. Find r_g the distance of the center of gravity of the wedge from O .
3. The z -axis is rotated till it is horizontal. The wedge is allowed to oscillate freely about O in the vertical xOy plane. What is the period of small oscillations?

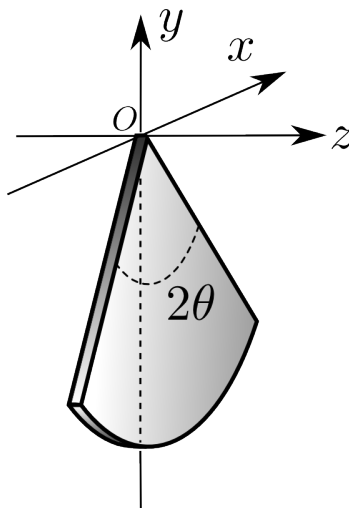

Problem 86. *1998-Spring-CM-U-3* ID:CM-U-1203

A particle of mass m has velocity v_0 when it is far from the center of a potential of the form:

$$V(r) = \frac{k}{r^4},$$

where k is a positive constant that you can conveniently write as

$$k = \frac{1}{2}mv_0^2a^4.$$

1. Find r_{min} the distance of the closest approach of the particle to the center of force, as a function of the impact parameter b of the particle.
2. Find an expression for the scattering angle of the particle as a function of the impact parameter b . Your expression may include a definite integral that you need not evaluate, so long as no unknown quantities appear in the integral.

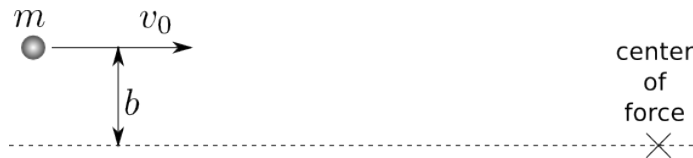
**Problem 87.** *1999-Fall-CM-U-1* ID:CM-U-1225

A long chain of length l has mass per unit length λ . It is suspended vertically above the pan of a spring scale, so that its bottom end just touches the pan. The chain is then released and falls freely under the influence of gravity. Determine the maximum weight reading of the scale assuming that the pan does not move and the chain does not bounce.

Problem 88. *1999-Fall-CM-U-2* ID:CM-U-1229

A particle of mass m moves in a circular orbit of radius r_0 under the influence of a potential $V(r) = V_0 \ln(r/r_0)$, where $V_0 > 0$.

1. Find the period of the orbit.
2. Find the frequency of small (radial) oscillations about the circular orbit.
3. Show that, while the circular orbit is a stable solution, the orbit with small radial oscillations is not periodic.

Problem 89. *1999-Fall-CM-U-3* ID:CM-U-1238

A mass m slides down the outside of a horizontal cylinder of radius R . Its initial velocity at the top of the cylinder ($\theta = 0$) is very small and can be neglected, and the whole motion takes place in a vertical plane. There is no friction between the mass and the cylinder, but there is a force opposing to the motion due to air resistance. The force is antiparallel to the velocity v and has magnitude $\beta mv^2/2R$, where β is a dimensionless parameter.

1. Show that the angle at which the mass leaves the cylinder is given by:

$$(1 + \beta^2) \cos \theta = 2 (e^{-\beta\theta} - \cos \theta + \beta \sin \theta)$$

[Hint: After substitution into your equation of motion, and subsequent multiplication by an appropriate function, you can obtain an integrable differential equation.]

2. Use the result from part **a.** to derive an approximate value needed for β such that the angle at which the mass leaves the cylinder is $1/100$ of a radian less than $\pi/2$.

Problem 90. 1999-Spring-CM-U-1

ID:CM-U-1253

A bead of mass m moves on a fixed frictionless wire shaped as a cycloid:

$$x = a(\theta - \sin \theta)$$

$$y = a(1 + \cos \theta)$$

The wire is oriented in a vertical plane, with the $+y$ direction pointing upward and the gravitational force downward.

1. Find the differential equation(s) of motion for the bead, but do not solve the equation(s).
2. Find the frequency of small amplitude oscillations of the bead on the wire about the equilibrium location.

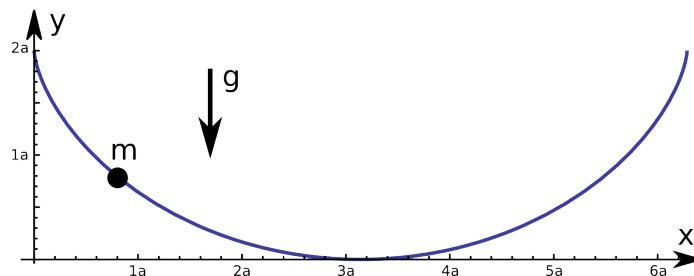

Problem 91. 1999-Spring-CM-U-2

ID:CM-U-1274

An infinitely long straight frictionless wire, which passes through the origin of the coordinate system, is held at a constant angle α with respect to the (vertical) z axis. The wire rotates about the z axis at constant angular velocity ω , so that it describes the surface of a pair of right circular cones, centered on the vertical axis, with their common vertices at the origin. Hence, an arbitrary point P , fixed on the wire, describes a horizontal circle as the wire rotates. A bead of mass m is free to slide along this wire under the influence of gravity and without friction. Let r be the distance of the bead from the apex of the cone, positive if above and negative if below the vertex.

1. Write the Lagrangian for this system in terms of r , α , ω , m , and g .
2. From the Lagrangian, obtain the differential equation of motion for the bead.
3. Solve the equation of motion subject to the initial conditions that $r = r_0$ and $dr/dt = 0$ at $t = 0$. Find the condition on r_0 which determines whether the bead will rise or fall on the wire.
4. Use your solution to the equation of motion to find $r(t)$ in the limit that ω goes to zero and show that it is consistent with simple kinematics.

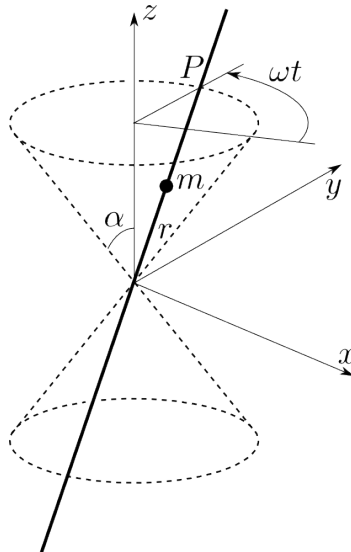

Problem 92. 1999-Spring-CM-U-3

ID:CM-U-1293

A classical oscillator consisting of two masses m_1 and m_2 , connected by an ideal spring (spring constant k), slides on a frictionless ramp as shown. The lower portion of the ramp is horizontal (gravity acts vertically), while on the left is an immovable vertical wall. The motion of the oscillator occurs entirely within the plane of the figure. The system starts stationary at height h , with the spring un-stretched.

Assume collisions with the wall, of which there may be more than one, are instantaneous and elastic. Neglect the small height difference between masses, and also neglect any differential force on them caused by the curvature of the ramp. Furthermore, assume the spring is sufficiently stiff that it does not collapse, so that the masses never touch each other.

1. For m_1 sufficiently greater than m_2 , there will be only one collision with the wall before the oscillator starts back up the ramp. In this case, find the maximum height attained by the oscillator on its first rebound.
2. For $m_1 = m_2 = m$, determine the behavior of the oscillator as it interacts with the wall. Find the maximum height attained by the rebounding oscillator in this situation, and sketch x_1 and x_2 vs. time while the oscillator interacts with the wall.

3. In the case that $m_1 \ll m_2$, describe qualitatively the behavior while the oscillator interacts with the wall, and give qualitative sketches of x_1 , and x_2 vs. time, demonstrating this behavior.

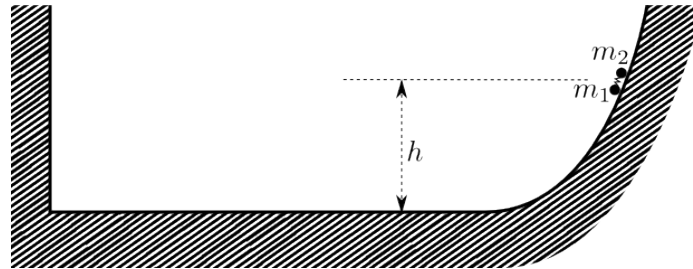

Problem 93. 2000-Fall-CM-U-1

ID:CM-U-1317

You have three masses along a one-dimensional space with masses m_1 , m_2 , and m_3 in that order. The second and third masses are initially at rest, and the first mass approaches from the left at some velocity. Mass m_1 collides with mass m_2 , which after recoiling collides with mass m_3 . Assume all collisions are elastic. For any general values of m_1 , and m_3 , what value must m_2 have for the maximum transfer of kinetic energy to m_3 ? Assume these are non-relativistic collisions.

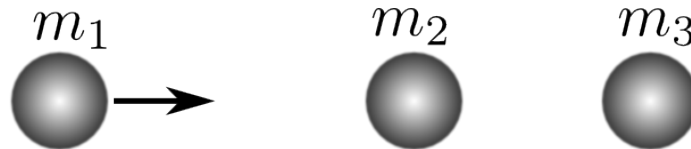

Problem 94. 2000-Fall-CM-U-2

ID:CM-U-1327

A uniform disk of mass M , and radius R is free to move without slipping on a flat horizontal surface. A pendulum is suspended from a frictionless pivot mounted on the axis of the cylinder. The pendulum consists of a massless rod of length L with a point mass m attached to its end.

1. Write the Lagrangian for this system in terms of x , ϕ , L , m , M and g .
2. From the Lagrangian obtain the equations of motion for the system, but DO NOT ATTEMPT TO SOLVE THEM.
3. Now obtain the equations of motion assuming small displacements of the generalized coordinates.
4. One “normal mode” of this system consists of a uniform translation. Find the frequency of oscillation of this system about an equilibrium position for its other normal mode.
5. Give a QUALITATIVE description of the motion associated with the normal mode in the previous part. **NOTE:** Do not solve for the exact algebraic form.

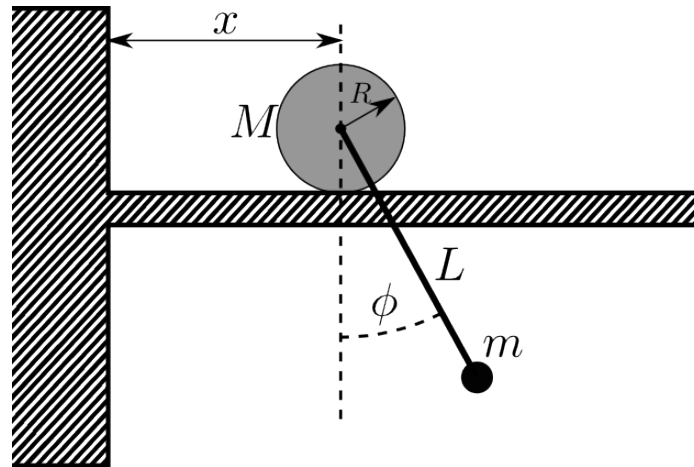
**Problem 95.** *2000-Fall-CM-U-3*

ID:CM-U-1349

A person on Earth observes two spacecraft (A and B) moving directly towards each other, and colliding. At time $t = 0$ in the Earth frame, the observer on Earth determines that spacecraft A, traveling to the right at speed $v_A = 4c/5$ is at a point a , and that spacecraft B, traveling to the left at speed $v_B = 3c/5$, is at point b . The points a and b are separated by a distance L in the Earth's frame.

1. In the Earth frame, how much time will elapse before the spacecraft collide?
2. How much time will elapse in A's frame from the time the spacecraft A passes the point a until the collision? How much time will elapse in B's frame from the time B passes b until the collision?

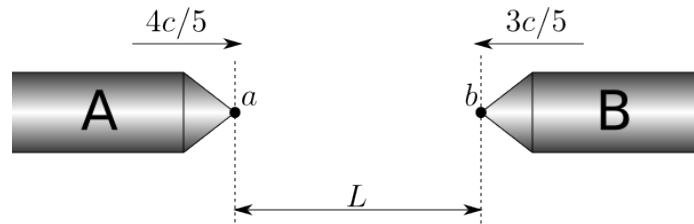
**Problem 96.** *2000-Spring-CM-U-1*

ID:CM-U-1365

A populated spherical planet, diameter a , is protected from incoming missiles by a repulsive force field described by the potential energy function:

$$V(r) = ka(a + r)e^{-r/a}, \quad r > a/2.$$

Here $k > 0$ and r is the distance of the missile from the center of the planet. Neglect all other forces on the missile.

The initial speed of a missile of mass m relative to the planet is v_0 when it is a long way away, and the missile is aimed in such a way that the closest it would approach the center of the planet, if it were not deflected at all by the force field or contact with the surface, would be at an impact parameter b (see the diagram). The missile

will not harm the planet if it does not come into contact with its surface. Therefore, we wish to explore, as a function of v_0 the range of values of b :

$$0 \leq b \leq B$$

such that the missile will hit the planet.

1. If v_0 is less than a certain critical velocity, v_c , the missile will not be able to reach the planet at all, even if $b = 0$. Determine v_c .
2. For missiles with velocity greater than v_c find B as a function of v_0 . Write this function of v_0 in terms of v_c and a .

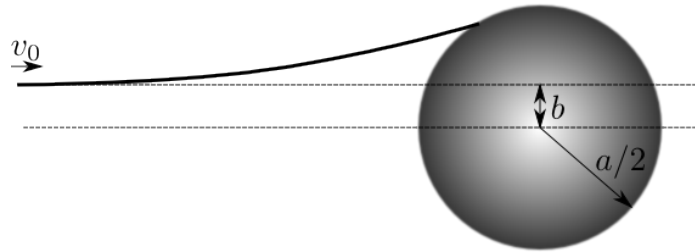

Problem 97. 2000-Spring-CM-U-2

ID:CM-U-1392

A particle of mass m is constrained to move in a straight, frictionless tube which is inclined at a fixed angle θ to the horizontal. The tube moves in its own vertical plane with constant horizontal acceleration a (gravity acts downward). The particle and tube are initially at rest at the origin of the coordinate system

1. Obtain the Lagrangian of this system
2. Obtain the equations of motion for this system.
3. Solve them to obtain the x and y coordinates as a function of time and the parameters of the problem.
4. Show that an alternative view of the motion of the particle as occurring in an accelerated frame of reference gives a consistent result.

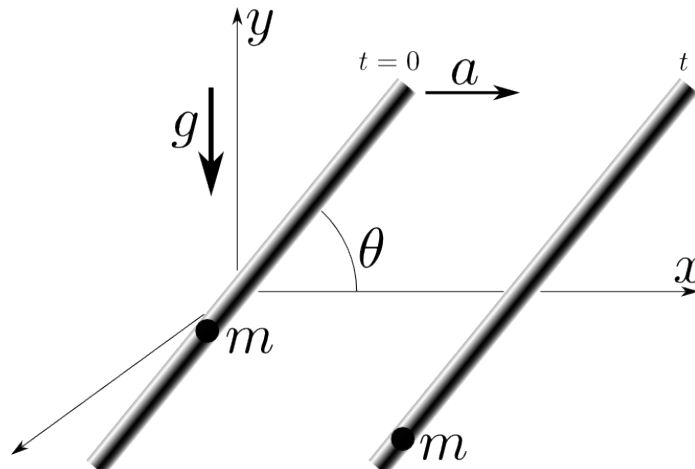

Problem 98. *2000-Spring-CM-U-3*

ID:CM-U-1412

Two beads, each of mass m , are free to move around a fixed frictionless vertical hoop of radius R . The two beads are connected by a massless spring, with natural length πR and spring constant k , that wraps around the hoop as shown below. The spring is also free to move without friction around the hoop. Assume gravity acts downward and that $mg/(kR) \ll 1$.

1. Find the exact equations of motion for the system. Be sure the you provide a clear definition of the coordinates that you adopt.
2. Find the frequencies of small amplitude oscillation of the system.

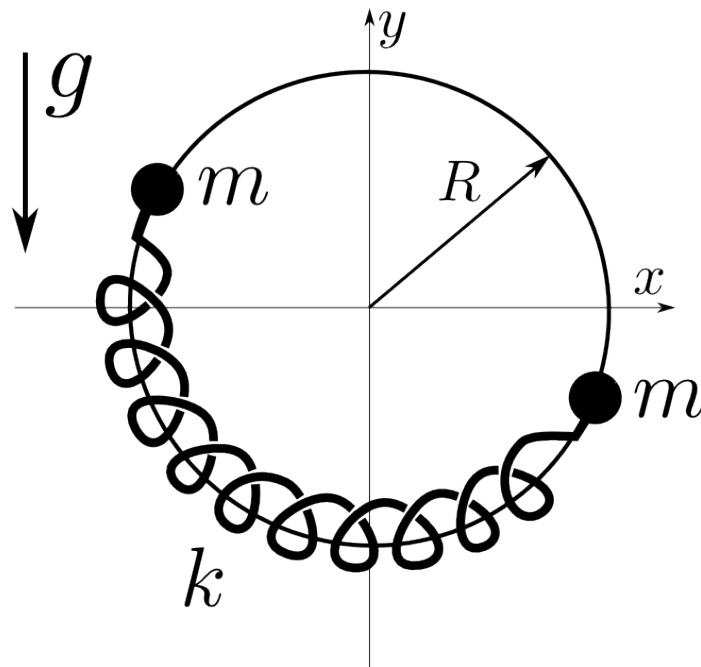
**Problem 99.** *2001-Fall-CM-U-1.*

ID:CM-U-1428

A particle is projected vertically upward in a constant gravitational field with an initial velocity v_0 . There is dissipative force acting on the particle that is proportional to the square of the instantaneous velocity.

1. Write down the particle's terminal velocity v_t .
2. Construct a differential equation for the particle's velocity v as a function of its height.
3. Express the velocity of the particle when it returns to the initial position in terms of v_0 and v_t .

Problem 100. *2001-Fall-CM-U-2*

ID:CM-U-1438

Two particles (masses M_1 and M_2) are moving under the influence of their mutual gravitational force. See the figure below.

1. Show that the Lagrangian for this two body system can be reduced to a one body system with reduced mass μ moving in a potential $U(r)$.
2. Assume the two particles are moving in circular orbits about one another, separated by a distance r_0 , and with period T . Find the period T in terms of M_1 , M_2 , and r_0 .
3. Now assume the particles are suddenly stopped in their orbits and allowed to fall toward one another under the influence of gravity. Find the time τ that it takes them to collide and express this answer in terms of T . Assume that r_0 is much larger than the diameter of either particle.

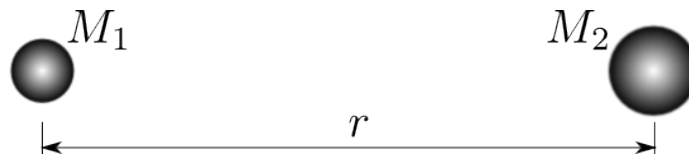
**Problem 101.** *2001-Fall-CM-U-3*

ID:CM-U-1457

Three spheres of equal mass m are constrained to move in one dimension along the line connecting their centers. The three spheres are connected by three springs, as shown in the figure. The three springs have equal spring constants k . In equilibrium, all three of the springs are at their respective natural lengths.

1. Choose a reasonable set of coordinates and find the equations of motion.
2. Find the normal-mode frequencies.

**Problem 102.** *2001-Spring-CM-U-1*

ID:CM-U-1472

We wish to extend a flexible wire of length L from a point on the equator of the earth, reaching into space in a straight line. Its uniform linear density is ρ . Assume the earth is spherical, radius R , and rotating at Ω radians per second. The acceleration due to gravity at the surface of the earth is g , which of course decreases according to Newton's Law of gravity as the distance from the center of the earth is varied.

Once set in equilibrium with respect to the rotating earth we assume the wire is strong enough not to break, and is held only at its contact point with the earth's surface, where the tension is T_s . There are no other forces on the wire except gravity.

1. Find the tension T of the wire at an arbitrary distance along the wire, assuming that the wire is long enough so that it will not fall down.
2. Find T_s , the tension at the earth's surface.
3. If the wire is too short it will fall down. Find the critical length, L_c , of the wire in this case. You may assume for the purpose of solving the equations involved, that the length, L_c , of the wire is much bigger than the radius of the earth, R .

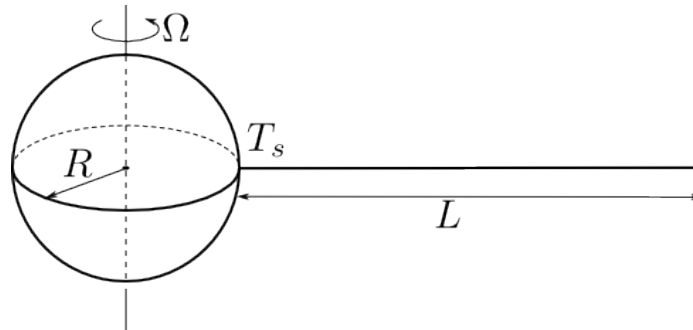

Problem 103. 2001-Spring-CM-U-2

ID:CM-U-1492

Consider the system, pictured below, which consists of a ball of mass m connected to a massless rod of length l . This is then joined at point r to a spring of spring constant k connected to a block of mass M which rests on a frictionless table. When $\theta = 0$ and $x = 0$ the spring is unstretched.

1. Write the Lagrangian for the system in terms of the coordinates θ and x assuming small displacements of the pendulum
2. Write the equations of motion for the system.
3. Making the simplifying assumptions that $M = m$, $l = 2r$, and setting $k/m = g/l = \omega_0^2$, find the normal-mode frequencies of this system for small oscillations in terms of ω_0
4. Assuming the same conditions, calculate the ratio of amplitudes (for each of the two masses) of the two normal modes of oscillation. In other words, find the normal modes.

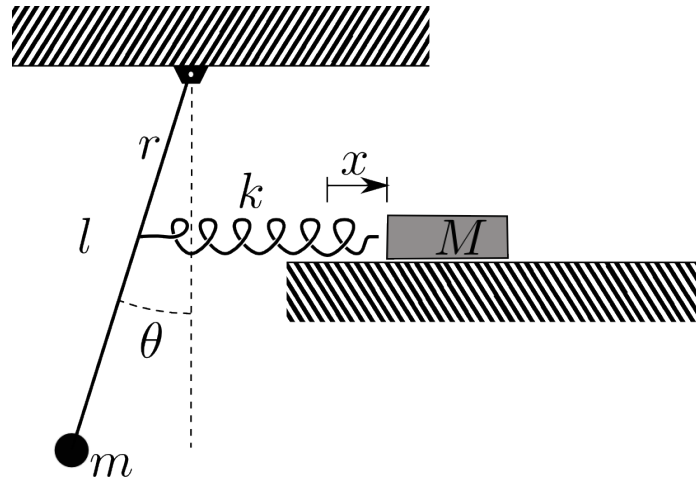

Problem 104. 2001-Spring-CM-U-3

ID:CM-U-1512

A particle with mass m , confined to a plane, is subject to a force field given by

$$\vec{F}(\vec{r}) = \begin{cases} -k\vec{r}, & \text{for } |r| \leq a \\ 0, & \text{for } |r| > a \end{cases}$$

The particle enters the field from the left horizontally with an initial velocity v_0 and a distance $b < a$ below the force center as shown.

1. Write down the equation of motion for $r \leq a$ in Cartesian coordinates in terms of x , y , and $\omega = \sqrt{k/m}$
2. Give the trajectory of the particle when $r < a$.
3. For $v_0 = a\omega$ find the coordinates of the particle as it exits the region of non-zero force field.
4. For $v_0 = a\omega$, find the deflection angle θ of the departing velocity at the exit point.

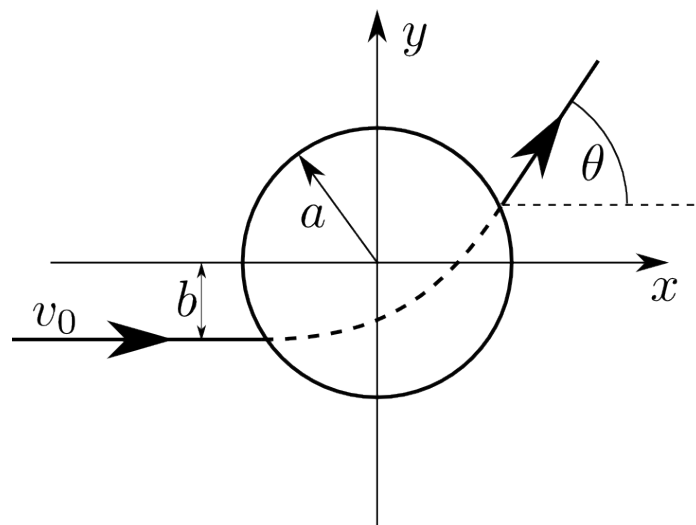

Problem 105. *Three pendulums* ID:CM-U-1532

Three identical pendulums are connected by the springs as shown on the figure. Find the normal modes

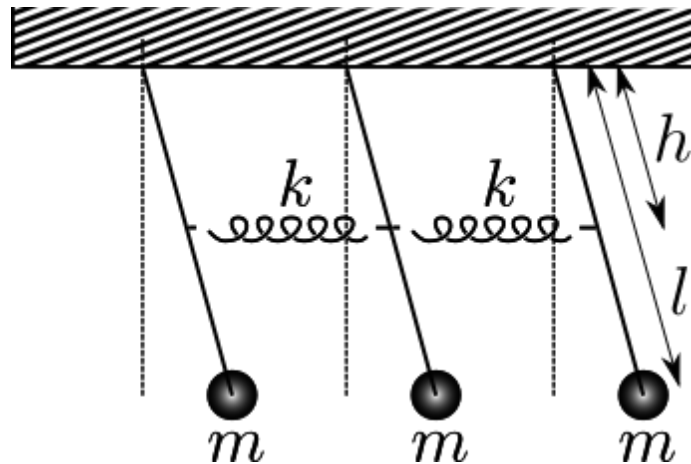
**Problem 106.** *A pendulum a spring and a block* ID:CM-U-1552

A ball of mass m is hanging on a weightless spring of spring constant k , which is attached to a block of mass M . The block can move along the table without friction. The length of the unstretched spring is l_0 . Find the normal modes of small oscillations.

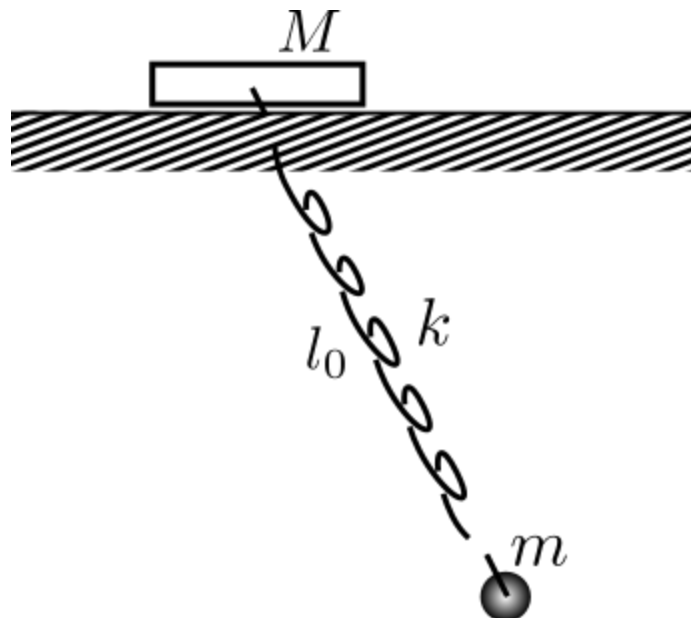
**Problem 107.** *A double pendulum* ID:CM-U-1572

Find normal frequencies and normal modes of a double pendulum.

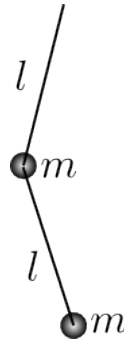
**Problem 108.** *Springs on Rails*

ID:CM-U-1592

Three infinite horizontal rails are at distance l from each other. Three beads of equal masses m can slide along the rails without friction. The three beads are connected by identical springs of constants k and equilibrium/unstretched length $l/2$.

1. Find the normal modes and the normal frequencies.
2. At time $t = 0$ one of the masses is suddenly given a velocity v . What will be the velocity of the whole system of three masses (average velocity) in the long time?

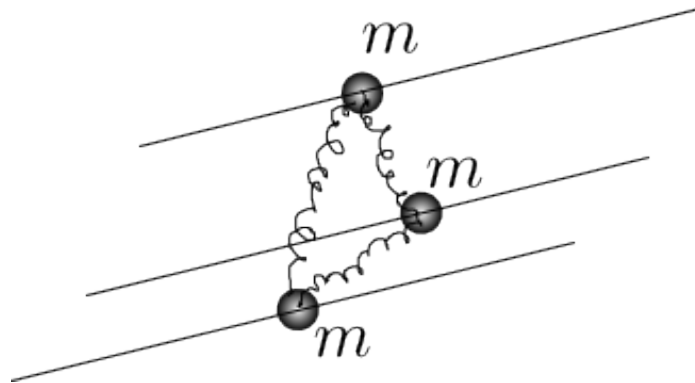
**Problem 109.** *Cylinders and a pendulum*

ID:CM-U-1612

A uniform solid cylinder of radius r and mass m can roll inside a hollow cylinder of radius $R > r$ without slipping. A pendulum of length $l = \frac{R-r}{2}$ and mass $M = m/2$ is attached to the center of the smaller cylinder. Find the normal frequencies and normal modes of this system.

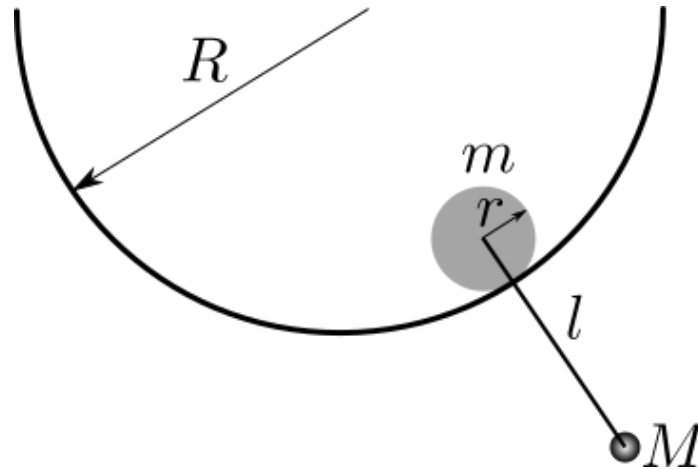

Problem 110. *A rod and a pendulum*

ID:CM-U-1632

A uniform rod AB of mass M and length $3a$ can rotate around a point O , $|AO| = a$. A pendulum of length $l = a$ and mass $m = \frac{3}{4}M$ is attached to the end A of the rod. Find the normal frequencies and normal modes.

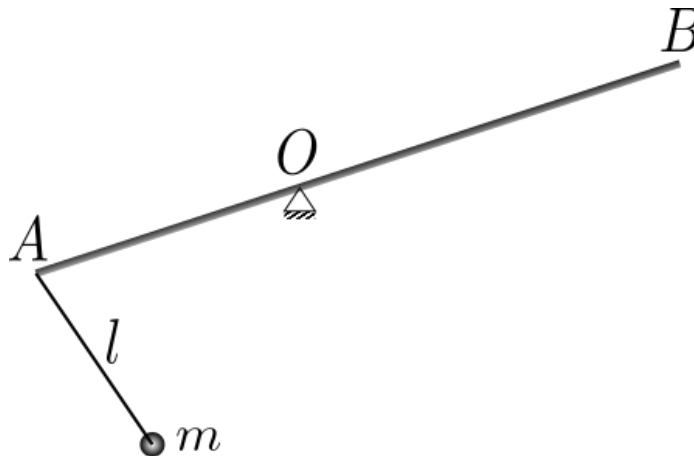

Problem 111. *A coin*

ID:CM-U-1652

A uniform thin disc of mass m rolls without slipping on a horizontal plane. The disc makes an angle α with the plane, the center of the disc C moves around the horizontal circle with a constant speed v . The axis of symmetry of the disc CO intersects the horizontal plane in the point O . The point O is stationary. Find the kinetic energy of the disc.

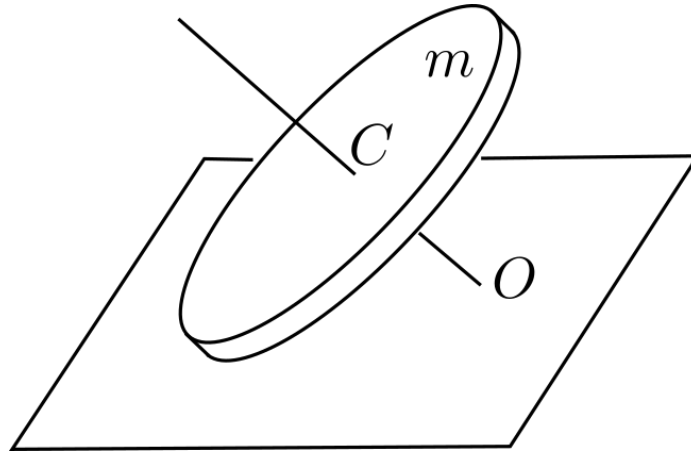

Problem 112. *A Rectangular Parallelepiped* ID:CM-U-1672

A uniform Rectangular Parallelepiped of mass m and edges a , b , and c is rotating with the constant angular velocity ω around an axis which coincides with the parallelepiped's large diagonal.

1. What is the parallelepiped's kinetic energy?
2. What torque must be applied to the axis of rotation in order to keep the axis(!) still? (neglect the gravity.)

Problem 113. *A disk in a frame* ID:CM-U-1692

A square weightless frame $ABCD$ with the side a is rotating around the side AB with the constant angular velocity ω_1 . A uniform disk of radius R and mass m is rotating around the frame's diagonal AC with the constant angular velocity ω_2 . The center of the disk coincides with the center of the frame. Assuming $\omega_1 = \omega_2 = \omega$ find

1. The kinetic energy of the system.
2. The magnitude of the torque that needs to be applied to the axis AB to keep it (the axis AB) still. (neglect the gravity.)

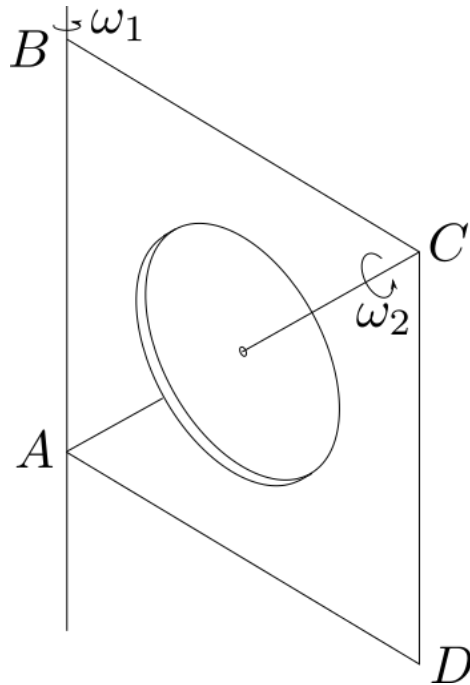

Problem 114. *Collapse of a star* ID:CM-U-1712

A very large number of small particles forms a spherical cloud. Initially they are at rest, have uniform mass density per unit volume ρ_0 , and occupy a region of radius r_0 . The cloud collapses due to gravitation; the particles do not interact with each other in any other way. How much time passes until the cloud collapses fully?

Problem 115. *A rod and a planet* ID:CM-U-1732

Two small, equal masses are attached by a lightweight rod. This object orbits a planet; the length of the rod is smaller than the radius of the orbit, but not negligible. The rod rotates about its axis in such a way that it remains vertical with respect to the planet.

1. Is there a force in the rod? If so, is it tension or compression?
2. Is the equilibrium stable, unstable, or neutral with respect to a small perturbation in the angle of the rod? (Assume this perturbation maintains the rate of rotation, so that in the co-rotating frame the rod is still stationary but at an angle to the vertical.)

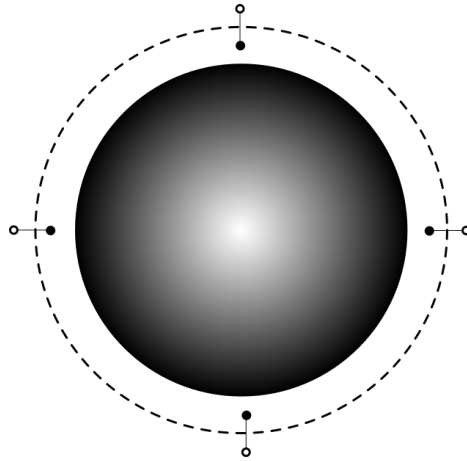
**Problem 116.** *Disc at an angle*

ID:CM-U-1752

A disk is rigidly attached to an massless axle passing through its center so that the disc's symmetry axis \hat{n} makes an angle θ with the axle. The moments of inertia of the disc relative to its center are C about the symmetry axis \hat{n} and A about any direction \hat{n}' perpendicular to \hat{n} . The axle spins with constant angular velocity $\vec{\omega} = \omega \hat{Z}$ (\hat{Z} is a unit vector along the axle.)

1. What is the kinetic energy of the disc?
2. What is the angular momentum, \vec{L} , expressed in the internal frame of reference of principle axes of inertia.
3. Find the torque, $\vec{\tau}$, which must be exerted on the axle by the bearings which support it. Specify the components of $\vec{\tau}$ along the principle axes of inertia of the disc.

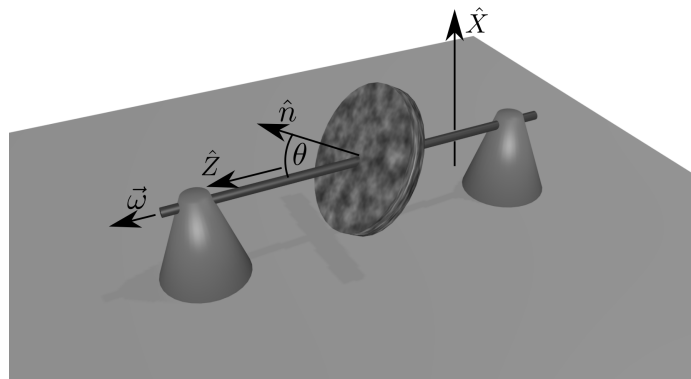

2 Graduate level

Problem 117. *1983-Fall-CM-G-4*

ID:CM-G-2

A yo-yo (inner radius r , outer radius R) is resting on a horizontal table and is free to roll. The string is pulled with a constant force F . Calculate the horizontal acceleration and indicate its direction for three different choices of F . Assume the yo-yo maintains contact with the table and can roll but does not slip.

1. $F = F_1$ is horizontal,
2. $F = F_2$ is vertical,
3. $F = F_3$ (its line of action passes through the point of contact of the yo-yo and table.)

Approximate the moment of inertia of the yo-yo about its symmetry axis by $I = \frac{1}{2}MR^2$ here M is the mass of the yo-yo.

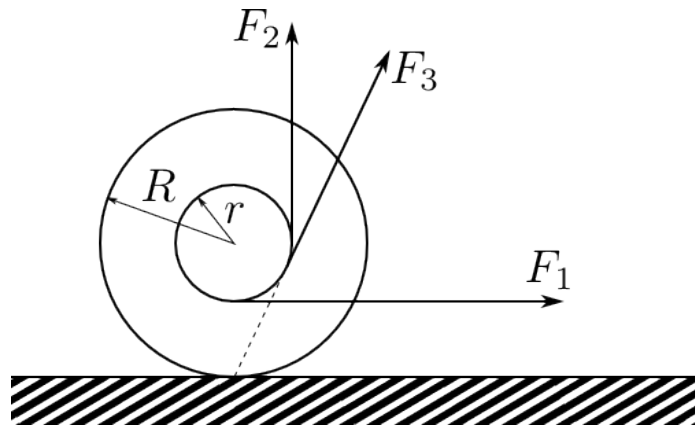

Problem 118. *1983-Fall-CM-G-5*

ID:CM-G-20

Assume that the earth is a sphere, radius R and uniform mass density, ρ . Suppose a shaft were drilled all the way through the center of the earth from the north pole to the south. Suppose now a bullet of mass m is fired from the center of the earth, with velocity v_0 up the shaft. Assuming the bullet goes beyond the earth's surface, calculate how far it will go before it stops.

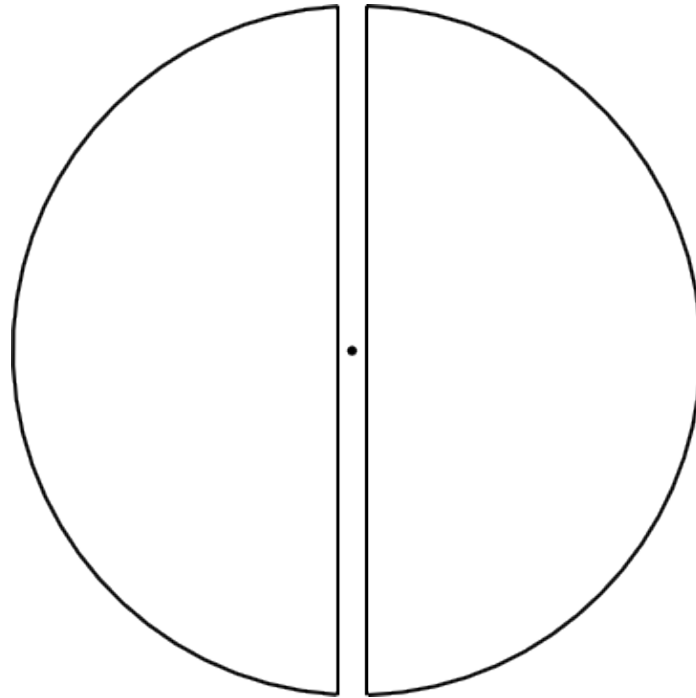

Problem 119. 1983-Spring-CM-G-4

ID:CM-G-29

A simple Atwood's machine consists of a heavy rope of length l and linear density ρ hung over a pulley. Neglecting the part of the rope in contact with the pulley, write down the Lagrangian. Determine the equation of motion and solve it. If the initial conditions are $\dot{x} = 0$ and $x = l/2$, does your solution give the expected result?

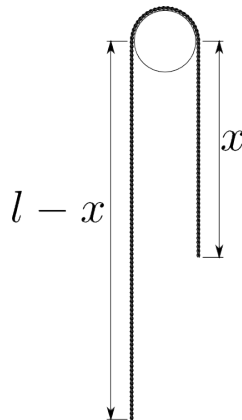

Problem 120. 1983-Spring-CM-G-5

ID:CM-G-38

A point mass m is constrained to move on a cycloid in a vertical plane as shown. (Note, a cycloid is the curve traced by a point on the rim of a circle as the circle rolls without slipping on a horizontal line.) Assume there is a uniform vertical downward gravitational field and express the Lagrangian in terms of an appropriate generalized coordinate. Find the frequency of small oscillations about the equilibrium point.

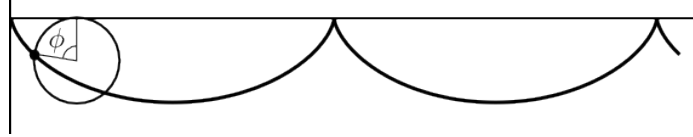
**Problem 121.** 1983-Spring-CM-G-6

ID:CM-G-49

Two pendula made with massless strings of length l and masses m and $2m$ respectively are hung from the ceiling. The two masses are also connected by a massless spring with spring constant k . When the pendula are vertical the spring is relaxed. What are the frequencies for small oscillations about the equilibrium position? Determine the eigenvectors. How should you initially displace the pendula so that when they are released, only one eigen frequency is excited. Make the sketches to specify these initial positions for both eigen frequencies.

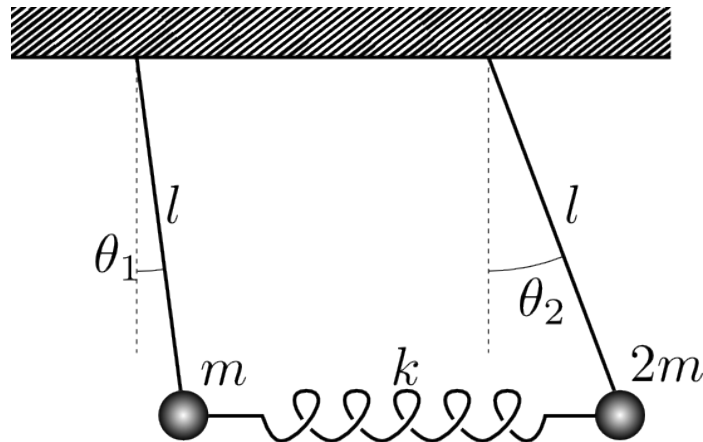
**Problem 122.** 1984-Fall-CM-G-4

ID:CM-G-60

Consider a mass M which can slide without friction on a horizontal shelf. Attached to it is a pendulum of length l and mass m . The coordinates of the center of mass of the block M are $(x, 0)$ and the position of mass m with respect to the center of mass of M is given by (x', y') . At $t = 0$ the mass M is at $x = 0$ and is moving with velocity v , and the pendulum is at its maximum displacement θ_0 . Consider the motion of the system for small θ .

1. What are the eigenvalues. Give a physical interpretation of them.
2. Determine the eigenvectors.
3. Obtain the complete solution for $x(t)$ and $\theta(t)$.

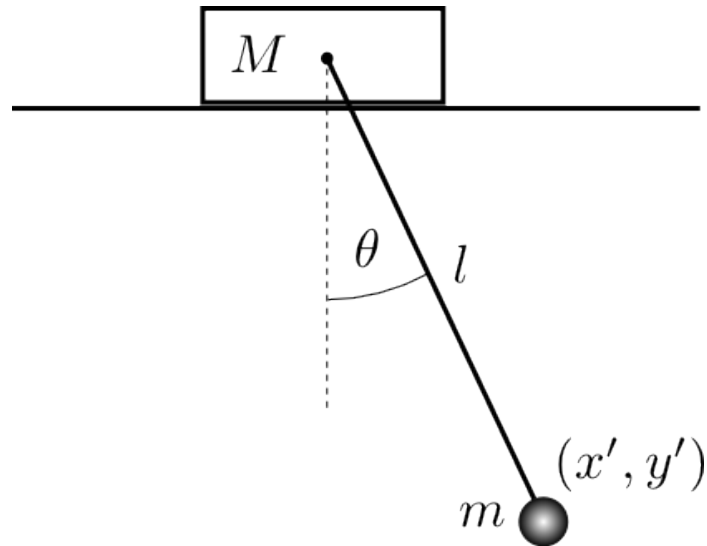
**Problem 123.** 1984-Fall-CM-G-5

ID:CM-G-74

A ladder of length L and mass M rests against a smooth wall and slides without friction on wall and floor. Initially the ladder is at rest at an angle $\alpha = \alpha_0$ with the floor. (For the ladder the moment of inertia about an axis perpendicular to and through the center of the ladder is $\frac{1}{12}ML^2$).

1. Write down the Lagrangian and Lagrange equations for $\alpha(t)$.
2. Find the first integral of motion in the angle α .
3. Determine the force exerted by the wall on the ladder as a function of α .
4. Determine the angle α_c at which the ladder leaves the wall.

Problem 124. 1984-Fall-CM-G-6

ID:CM-G-90

A rocket of mass m moves with initial velocity v_0 towards the moon of mass M , radius R . Take the moon to be at rest and neglect all other bodies.

1. Determine the maximum impact parameter for which the rocket will strike the moon.
2. Determine the cross-section σ for striking the moon.
3. What is σ in the limit of infinite velocity v_0 ?

The following information on hyperbolic orbits will be useful:

$$r = \frac{a(\epsilon^2 - 1)}{1 + \epsilon \cos \theta}, \quad \epsilon^2 = 1 + \frac{2\mathcal{E}L^2}{G^2m^3M^2},$$

where r is the distance from the center of force F to the rocket, θ is the angle from the center of force, \mathcal{E} is the rocket energy, L is angular momentum, and G is the gravitational constant.

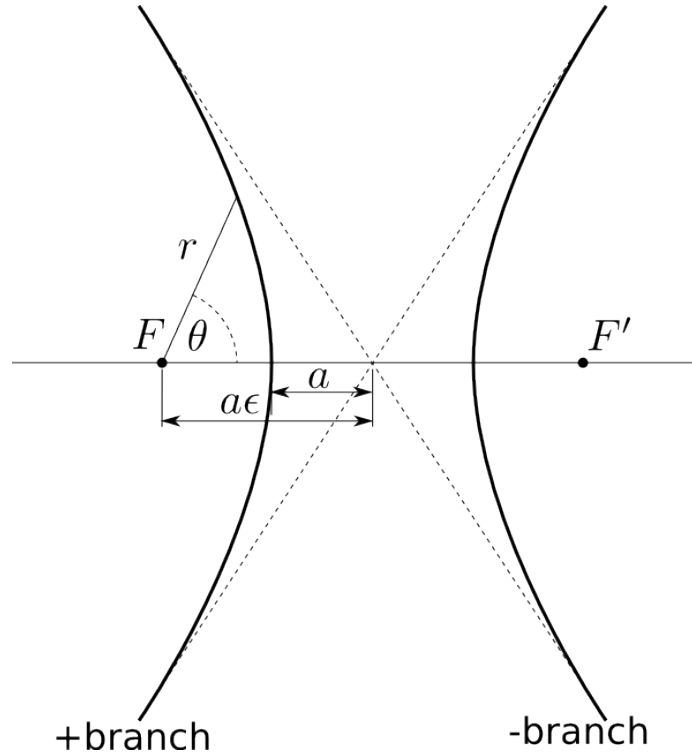
**Problem 125.** 1984-Spring-CM-G-4

ID:CM-G-111

A mass m moves in two dimensions subject to the potential energy

$$V(r, \theta) = \frac{kr^2}{2} (1 + \alpha \cos^2 \theta)$$

1. Write down the Lagrangian and the Lagrange equations of motion.
2. Take $\alpha = 0$ and consider a circular orbit of radius r_0 . What is the frequency f_0 of the orbital motion? Take $\theta_0(0) = 0$ and determine $\theta_0(t)$.
3. Now take α nonzero but small, $\alpha \ll 1$; and consider the effect on the circular orbit. Specifically, let

$$r(t) = r_0 + \delta r(t) \quad \text{and} \quad \theta(t) = \theta_0(t) + \delta \theta(t),$$

where $\theta_0(t)$ was determined in the previous part. Substitute these in the Lagrange equations and show that the differential equations for the $\delta r(t)$ and $\delta \theta(t)$ to the first order in δr , $\delta \theta$ and their derivatives are

$$\begin{aligned} \ddot{\delta r} - \omega r_0 \dot{\delta \theta} + \frac{\alpha \omega^2 r_0}{8} \cos(\omega t) + \frac{\alpha \omega^2 r_0}{8} &= 0 \\ r_0 \ddot{\delta \theta} + \omega \dot{\delta r} - \frac{\alpha \omega^2 r_0}{8} \sin(\omega t) &= 0, \end{aligned} \tag{1}$$

where $\omega = 2\sqrt{k/m}$.

4. Solve these differential equations to obtain $\delta r(t)$ and $\delta\theta(t)$. For initial conditions take

$$\delta r(0) = \dot{\delta r}(0) = \delta\theta(0) = \dot{\delta\theta}(0) = 0$$

The solutions correspond to sinusoidal oscillations about the circular orbit. How does the frequency of these oscillations compare to the frequency of the orbital motion, f_0 ?

Problem 126. *1984-Spring-CM-G-5*

ID:CM-G-139

A ring of mass m slides over a rod with mass M and length L , which is pivoted at one end and hangs vertically. The mass m is secured to the pivot point by a massless spring of spring constant k and unstressed length l . For $\theta = 0$ and at equilibrium m is centered on the rod. Consider motion in a single vertical plane under the influence of gravity.

1. Show that the potential energy is

$$V = \frac{k}{2}(r - L/2)^2 + mgr(1 - \cos\theta) - \frac{1}{2}MgL \cos\theta.$$

2. Write the system Lagrangian in terms of r and θ .
3. Obtain the differential equations of motion for r and θ .
4. In the limit of small oscillations find the normal mode frequencies. To what physical motions do these frequencies correspond?

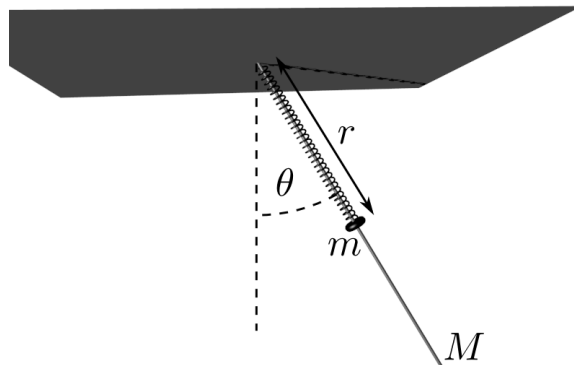

Problem 127. *1985-Fall-CM-G-4*

ID:CM-G-157

A system consists of a point particle of mass m and a straight uniform rod of length l and mass m on a frictionless horizontal table. A rigid frictionless vertical axle passes through one end of the rod.

The rod is originally at rest and the point particle is moving horizontally toward the end of the rod with a speed v and in a direction perpendicular to the rod as shown in the figure. When the particle collides with the end of the rod they stick together.

1. Discuss the relevance of each of the following conservation laws for the system: conservation of kinetic energy, conservation of linear momentum, and conservation of angular momentum.
2. Find the resulting motion of the combined rod and particle following the collision (*i.e.*, what is ω of the system after the collision?)
3. Describe the average force of the rod on the vertical axle during the collision.
4. Discuss the previous three parts for the case in which the frictionless vertical axle passes through the center of the rod rather than the end.

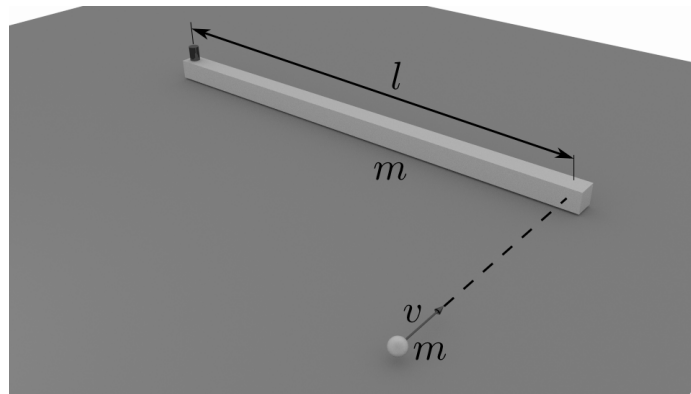
**Problem 128.** 1985-Fall-CM-G-5

ID:CM-G-175

Consider a motion of a point particle of mass m in a central force $\vec{F} = -k\vec{r}$, where k is a constant and \vec{r} is the position vector of the particle.

1. Show that the motion will be in a plane.
2. Using cylindrical coordinates with \hat{z} perpendicular to the plane of motion, find the Lagrangian for the system.
3. Show that P_θ is a constant of motion and equal to the magnitude of the angular momentum L .
4. Find and describe the motion of the particle for a specific case $L = 0$.

Problem 129. 1985-Fall-CM-G-6

ID:CM-G-188

A disk is rigidly attached to an axle passing through its center so that the disc's symmetry axis \hat{n} makes an angle θ with the axle. The moments of inertia of the disc relative to its center are C about the symmetry axis \hat{n} and A about any direction \hat{n}' perpendicular to \hat{n} . The axle spins with constant angular velocity $\vec{\omega} = \omega\hat{z}$ (\hat{z} is a unit vector along the axle.) At time $t = 0$, the disk is oriented such that the symmetry axis lies in the $X - Z$ plane as shown.

1. What is the angular momentum, $\vec{L}(t)$, expressed in the space-fixed frame.

2. Find the torque, $\vec{\tau}(t)$, which must be exerted on the axle by the bearings which support it. Specify the components of $\vec{\tau}(t)$ along the space-fixed axes.

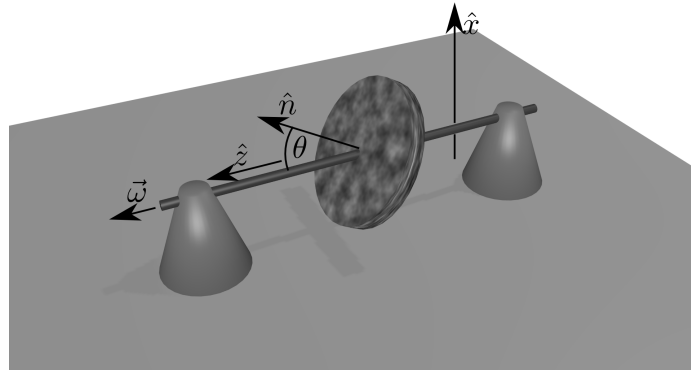

Problem 130. 1985-Spring-CM-G-4

ID:CM-G-200

Particle 1 (mass m_1 , incident velocity \vec{v}_1) approaches a system of masses m_2 and $m_3 = 2m_2$, which are connected by a rigid, massless rod of length l and are initially at rest. Particle 1 approaches in a direction perpendicular to the rod and at time $t = 0$ collides head on (elastically) with particle 2.

1. Determine the motion of the center of mass of the m_1 - m_2 - m_3 system.
2. Determine \vec{v}_1 and \vec{v}_2 , the velocities of m_1 and m_2 the instant following the collision.
3. Determine the motion of the center of mass of the m_2 - m_3 system before and after the collision.
4. Determine the motion m_2 and m_3 relative to their center of mass after the collision.
5. For a certain value of m_1 , there will be a second collision between m_1 and m_2 . Determine that value of m_1 .

Problem 131. 1985-Spring-CM-G-5

ID:CM-G-213

A bead slides without friction on a wire in the shape of a cycloid:

$$x = a(\theta - \sin \theta)$$

$$y = a(1 + \cos \theta)$$

1. Write down the Hamiltonian of the system.
2. Derive Hamiltonian's equations of motion.

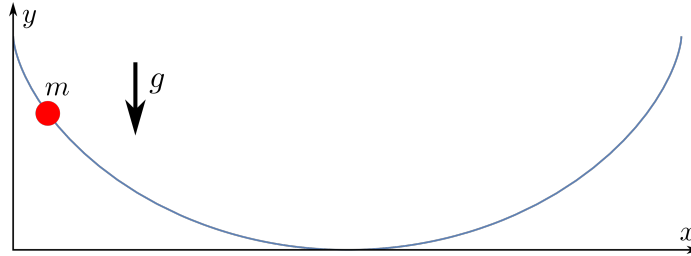
**Problem 132.** *1985-Spring-CM-G-6*

ID:CM-G-226

A dumbbell shaped satellite moves in a circular orbit around the earth. It has been given just enough spin so that the dumbbell axis points toward the earth. Show that this orientation of the satellite axis is stable against small perturbations in the orbital plane. Calculate the frequency ω of small oscillations about this stable orientation and compare ω to the orbital frequency $\Omega = 2\pi/T$, where T is the orbital period. The satellite consists of two point masses m each connected by massless rod of length $2a$ and orbits at a distance R from the center of the earth. Assume throughout that $a \ll R$.

Problem 133. *1986-Spring-CM-G-4*

ID:CM-G-232

A block of mass m rests on a wedge of mass M which, in turn, rests on a horizontal table as shown. All surfaces are frictionless. The system starts at rest with point P of the block a distance h above the table.

1. Find the velocity V of the wedge the instant point P touches the table.
2. Find the normal force between the block and the wedge.

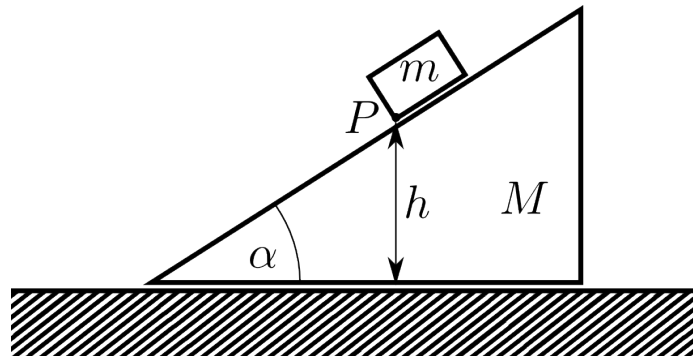
**Problem 134.** *1986-Spring-CM-G-5*

ID:CM-G-245

Kepler's Second law of planetary motion may be stated as follows, "The radius vector drawn from the sun to any planet sweeps out equal areas in equal times." If the force law between the sun and each planet were not inverse square law, but an inverse cube law, would the Kepler's Second Law still hold? If your answer is no, show how the law would have to be modified.

Problem 135. 1987-Fall-CM-G-4 ID:CM-G-252

Assume that the sun (mass M_{\odot}) is surrounded by a uniform spherical cloud of dust of density ρ . A planet of mass m moves in an orbit around the sun within the dust cloud. Neglect collisions between the planet and the dust.

1. What is the angular velocity of the planet when it moves in a circular orbit of radius r ?
2. Show that if the mass of the dust within the sphere of the radius r is small compared to M_{\odot} , a nearly circular orbit will precess. Find the angular velocity of the precession.

Problem 136. 1987-Fall-CM-G-6 ID:CM-G-265

A uniform solid cylinder of radius r and mass m is given an initial angular velocity ω_0 and then dropped on a flat horizontal surface. The coefficient of kinetic friction between the surface and the cylinder is μ . Initially the cylinder slips, but after a time t pure rolling without slipping begins. Find t and v_f , where v_f is the velocity of the center of mass at time t .

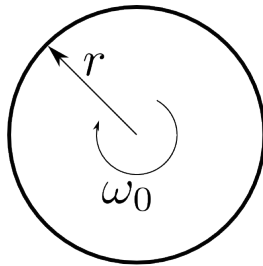
**Problem 137.** 1988-Fall-CM-G-4 ID:CM-G-274

A satellite is in a circular orbit of radius r_0 about the earth. Its rocket motor fires briefly, giving a tangential impulse to the rocket. This impulse increases the velocity of the rocket by 8% in the direction of its motion at the instant of the impulse.

1. Find the maximum distance from the earth's center for the satellite in its new orbit. (NOTE: The equation for the path of a body under the influence of a central force, $F(r)$, is:

$$\frac{d^2u}{d\theta^2} + u = -\frac{m}{L^2u^2}F(1/u),$$

where $u = 1/r$, L is the orbital angular momentum, and m is the mass of the body.

2. Determine the one-dimensional effective potential for this central force problem. Sketch the two effective potentials for this problem, before and after this impulse, on the same graph. Be sure to clearly indicate the differences between them in your figure

Problem 138. *1988-Fall-CM-G-5*

ID:CM-G-291

A cylindrical pencil of length l , mass m and diameter small compared to its length rests on a horizontal frictionless surface. This pencil is initially motionless. At $t=0$, a large, uniform, horizontal impulsive force F lasting a time Δt is applied to the end of the pencil in a direction perpendicular to the pencil's long dimension. This time interval is sufficiently short, that we may neglect any motion of the system during the application of this impulse. For convenience, consider that the center-of-mass of the pencil is initially located at the origin of the $x - y$ plane with the long dimension of the pencil parallel to the x -axis. In terms of F , Δt , l , and m answer the following:

1. Find the expression for the position of the center-of-mass of the pencil as a function of the time, t , after the application of the impulse.
2. Calculate the time necessary for the pencil to rotate through an angle of $\pi/2$ radians.

Problem 139. *1989-Fall-CM-G-4*

ID:CM-G-305

Consider the motion of a rod, whose ends can slide freely on a smooth vertical circular ring, the ring being free to rotate about its vertical diameter, which is fixed. Let m be the mass of the rod and $2a$ its length; let M be the mass of the ring and r its radius; let θ be the inclination of the rod to the horizontal, and ϕ the azimuth of the ring referred to some fixed vertical plane, at any time t .

1. Calculate the moment of inertia of the rod about an axis through the center of the ring perpendicular to its plane, in terms of r , a , and m .
2. Calculate the moment of inertia of the rod about the vertical diameter, in terms of r , a , m , and θ .
3. Set up the Lagrangian.
4. Find which coordinate is ignorable (*i.e.*, it does not occur in the Lagrangian) and use this result to simplify the Lagrange equations of motion of θ and ϕ . Show that θ and ϕ are separable but do not try to integrate this equation.
5. Is the total energy of the system a constant of motion? (justify your answer)

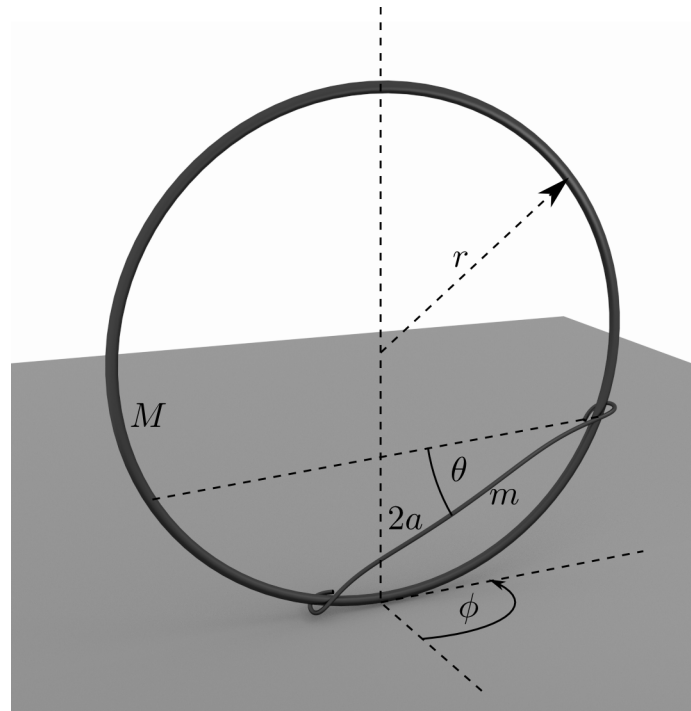
**Problem 140.** 1989-Fall-CM-G-5

ID:CM-G-328

Consider a particle of mass m interacting with an attractive central force field of the form

$$V(r) = -\frac{\alpha}{r^4}, \quad \alpha > 0.$$

The particle begins its motion very far away from the center of force, moving with a speed v_0 .

1. Find the effective potential V_{eff} for this particle as a function of r , the impact parameter b , and the initial kinetic energy $E_0 = \frac{1}{2}mv_0^2$. (Recall that V_{eff} includes the centrifugal effect of the angular momentum.)
2. Draw a qualitative graph of V_{eff} as a function of r . (Your graph need not show the correct behavior for the special case $b = 0$.) Determine the value(s) of r at any special points associated with the graph.
3. Find the cross section for the particle to spiral in all the way to the origin.

Problem 141. 1989-Spring-CM-G-4

ID:CM-G-346

A particle of mass m is constrained to move on the surface of a cylinder with radius R . The particle is subject only to a force directed toward the origin and proportional to the distance of the particle from the origin.

1. Find the equations of motion for the particle and solve for $\Phi(t)$ and $z(t)$.
2. The particle is now placed in a uniform gravitational field parallel to the axis of the cylinder. Calculate the resulting motion.

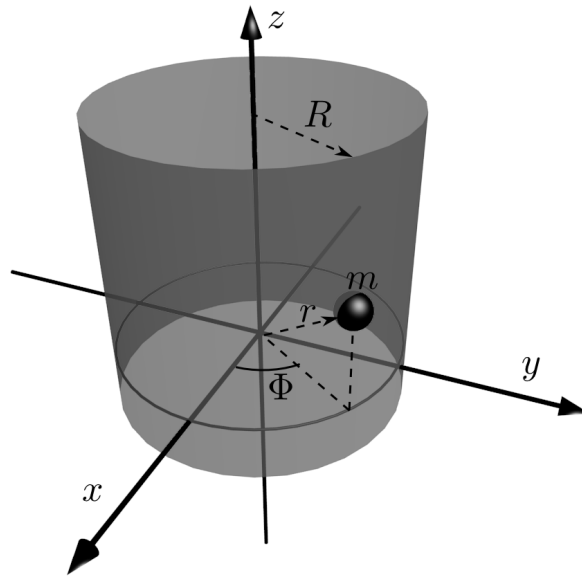

Problem 142. 1989-Spring-CM-G-5

ID:CM-G-364

A photon of energy E_γ collides with an electron initially at rest and scatters off at an angle ϕ as shown. Let $m_e c^2$ be the rest mass energy of the electron. Determine the energy \bar{E}_γ of the scattered photon in terms of the incident photon energy E_γ , electron rest mass energy $m_e c^2$, and scattering angle ϕ . Treat the problem relativistically.

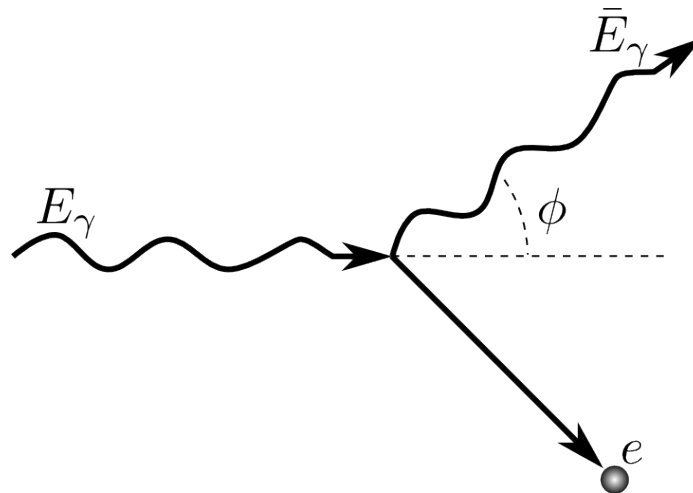

Problem 143. 1990-Fall-CM-G-4

ID:CM-G-373

A bar of negligible weight is suspended by two massless rods of length a . From it are hanging two identical pendula with mass m and length l . All motion is confined to a plane. Treat the motion in the small oscillation approximation. (Hint: use θ , θ_1 , and θ_2 as generalized coordinates.)

1. Find the normal mode frequencies of the system.
2. Find the eigenvector corresponding to the lowest frequency of the system.
3. Describe physically the motion of the system oscillating at its lowest frequency.

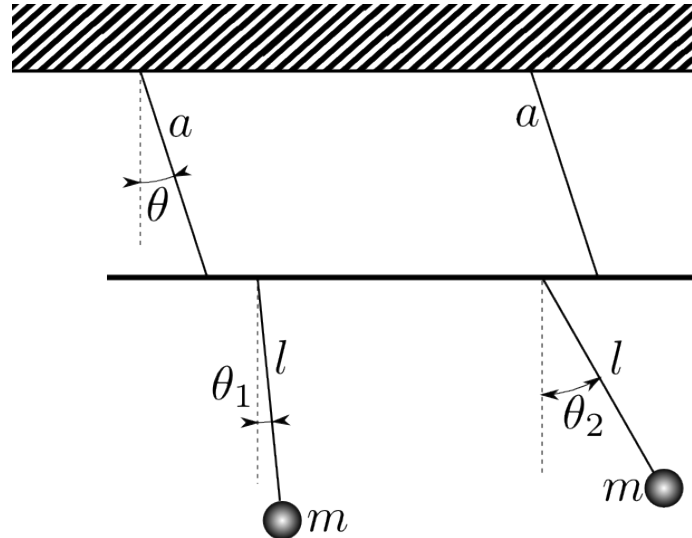
**Problem 144.** 1990-Fall-CM-G-5

ID:CM-G-390

A spherical pendulum consisting of a particle of mass m in a gravitational field is constrained to move on the surface of a sphere of radius R . Describe its motion in terms of the polar angle θ , measured from the vertical axis, and the azimuthal angle ϕ .

1. Obtain the equation of motion.
2. Identify the effective Potential $V_{eff}(\theta)$, and sketch it for $L_\phi > 0$ and for $L_\phi = 0$. (L_ϕ is the azimuthal angular momentum.)
3. Obtain the energy E_0 and the azimuthal angular velocity $\dot{\phi}_0$ corresponding to uniform circular motion around the vertical axis, in terms of θ_0 .
4. Given the angular velocity $\dot{\phi}_0$ an energy slightly greater than E_0 , the mass will undergo simple harmonic motion in θ about θ_0 . Find the frequency of this oscillation in θ .

Problem 145. 1990-Spring-CM-G-4

ID:CM-G-406

A particle of mass m slides down from the top of a frictionless parabolic surface which is described by $y = -\alpha x^2$, where $\alpha > 0$. The particle has a negligibly small initial velocity when it is at the top of the surface.

1. Use the Lagrange formulation and the Lagrange multiplier method for the constraint to obtain the equations of motion.

2. What are the constant(s) of motion of this problem?
3. Find the components of the constraint force as functions of position only on the surface.
4. Assume that the mass is released at $t = 0$ from the top of the surface, how long will it take for the mass to drop off the surface?

Problem 146. *1990-Spring-CM-G-5*

ID:CM-G-424

A particle of mass m moves on the inside surface of a smooth cone whose axis is vertical and whose half-angle is α . Calculate the period of the horizontal circular orbits and the period of small oscillations about this orbit as a function of the distance h above the vertex. When are the perturbed orbits closed?

Problem 147. *1991-Fall-CM-G-5*

ID:CM-G-433

A simple pendulum of length l and mass m is suspended from a point P that rotates with constant angular velocity ω along the circumference of a vertical circle of radius a .

1. Find the Hamiltonian function and the Hamiltonian equation of motion for this system using the angle θ as the generalized coordinate.
2. Do the canonical momentum conjugate to θ and the Hamiltonian function in this case correspond to physical quantities? If so, what are they?

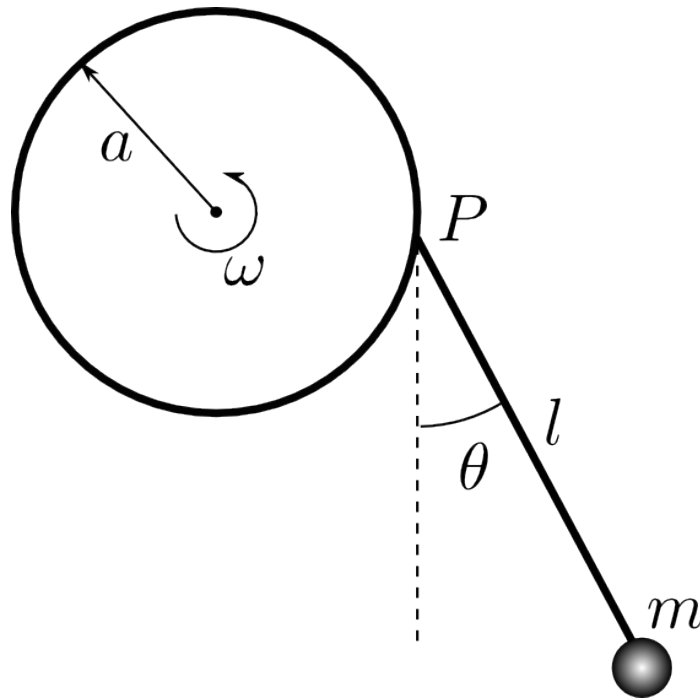

Problem 148. *1991-Spring-CM-G-4*

ID:CM-G-451

Three particles of masses $m_1 = m_0$, $m_2 = m_0$, and $m_3 = m_0/3$ are restricted to move in circles of radius a , $2a$, and $3a$ respectively. Two ideal springs of natural length much smaller than a and force constant k link particles 1, 2 and particles 2, 3 as shown.

1. Determine the Lagrangian of this system in terms of polar angles θ_1 , θ_2 , θ_3 and parameters m_0 , a , and k .
2. For small oscillations about an equilibrium position, determine the system's normal mode frequencies in term of $\omega_0 = \sqrt{k/m_0}$.
3. Determine the normalized eigenvector corresponding to each normal mode and describe their motion physically.
4. What will happen if the natural length of the springs is a ?

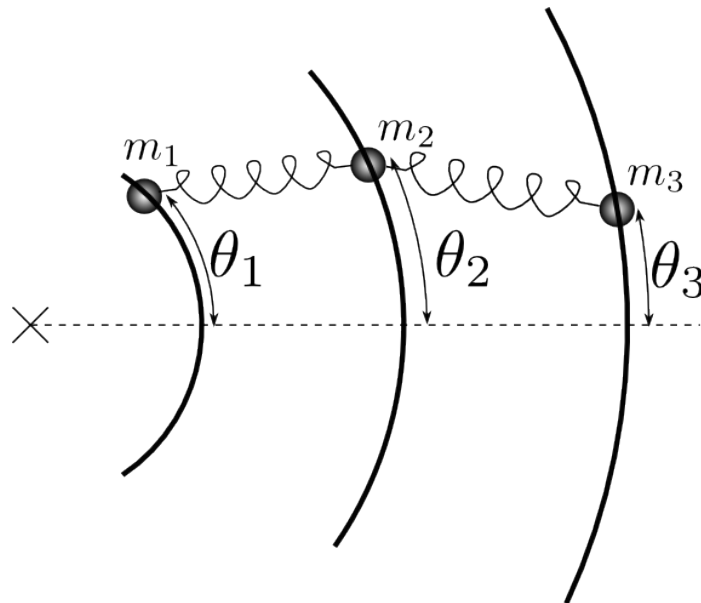
**Problem 149.** *1991-Spring-CM-G-5*

ID:CM-G-470

A particle is constrained to move on a cylindrically symmetric surface of the form $z = (x^2 + y^2)/(2a)$. The gravitational force acts in the $-z$ direction.

1. Use generalized coordinates with cylindrical symmetry to incorporate the constraint and derive the Lagrangian for this system.
2. Derive the Hamiltonian function, Hamilton's equation, and identify any conserved quantity and first integral of motion.
3. Find the radius r_0 of a steady state motion in r having angular momentum l .
4. Find the frequency of small radial oscillations about this steady state.

Problem 150. *1992-Fall-CM-G-4* ID:CM-G-487

1. What is the most general equation of motion of a point particle in an inertial frame?
2. Qualitatively, how does the equation of motion change for an observer in an accelerated frame (just name the different effects and state their qualitative form).
3. Give a general class of forces for which you can define a Lagrangian.
4. Specifically, can you define a Lagrangian for the forces

$$\vec{F}_1 = (ax, 0, 0), \quad \vec{F}_2 = (ay, 0, 0), \quad \vec{F}_3 = (ay, ax, 0).$$

Why or why not?

Problem 151. *1992-Fall-CM-G-5* ID:CM-G-506

A spherical pendulum consists of a particle of mass m in a gravitational field constrained to move on the surface of a sphere of radius R . Use the polar angle θ , measured down from the vertical axis, and azimuthal angle ϕ .

1. Obtain the equations of motion using Lagrangian formulation.
2. Identify the effective potential, $V_{eff}(\theta)$, and sketch it for the angular momentum $L_\phi > 0$, and for $L_\phi = 0$.
3. Obtain the values of E_0 and $\dot{\phi}_0$ in terms of θ_0 for uniform circular motion around the vertical axis.
4. Given the angular velocity $\dot{\phi}_0$ and an energy slightly greater than E_0 , the mass will undergo simple harmonic motion in θ about, θ_0 . Expand $V_{eff}(\theta)$ in a Taylor series to determine the frequency of oscillation in θ .

Problem 152. *1992-Spring-CM-G-5* ID:CM-G-527

A particle of mass m is moving on a sphere of radius a , in the presence of a velocity dependent potential $U = \sum_{i=1,2} \dot{q}_i A_i$, where $q_1 = \theta$ and $q_2 = \phi$ are the generalized coordinates of the particle and $A_1 \equiv A_\theta$, $A_2 \equiv A_\phi$ are given functions of θ and ϕ .

1. Calculate the generalized force defined by

$$Q_i = \frac{d}{dt} \frac{\partial U}{\partial \dot{q}_i} - \frac{\partial U}{\partial q_i}.$$

2. Write down the Lagrangian and derive the equation of motion in terms of θ and ϕ .

3. For $A_\theta = 0$, $A_\phi = \frac{g}{a} \frac{1-\cos\theta}{\sin\theta}$, where g is a constant, describe the symmetry of the Lagrangian and find the corresponding conserved quantity. (Can you figure out what is the magnetic field in this case?)
4. In terms of three dimensional Cartesian coordinates, *i.e.*, $q_i = x_i$ show that Q_i can be written as $\vec{Q} = \vec{v} \times \vec{B}$, where $v_i = \dot{x}_i$. Find \vec{B} in terms of \vec{A} .

Problem 153. 1993-Fall-CM-G-1

ID:CM-G-548

A particle of charge q and mass m moving in a uniform constant magnetic field B (magnetic field is along z -axis) can be described in cylindrical coordinates by the Lagrangian

$$\mathcal{L} = \frac{m}{2} \left[\dot{r}^2 + r^2 \dot{\theta}^2 + \dot{z}^2 \right] + \frac{q}{2c} B r^2 \dot{\theta}$$

1. In cylindrical coordinates find the Hamiltonian, Hamilton's equations of motion, and the resulting constants of motion.
2. Assuming $r = \text{const.} \equiv r_0$, solve the equations of motion and find the action variable J_θ (conjugate generalized momentum) corresponding to θ .

Problem 154. 1993-Fall-CM-G-2

ID:CM-G-563

Three particles each of equal mass m are connected by four massless springs and allowed to move along a straight line as shown in the figure. Each spring has unstretched length equal to l and spring constants shown in the figure.

1. Solve the problem for small vibrations of the masses, *i.e.*, determine the normal frequencies and the normal modes (amplitudes) of the vibrations. Also indicate each normal mode in a figure.
2. Consider the following two cases with large amplitude: (i) The first case where the masses and springs can freely pass through each other and through the left and right, boundary; and (ii) the second case where the masses and the boundaries are impenetrable, *i.e.*, the mass can not pass through each other or through the boundaries. Explain whether the small vibration solution obtained in a previous part is also the general solution for the motion in either of the two cases.

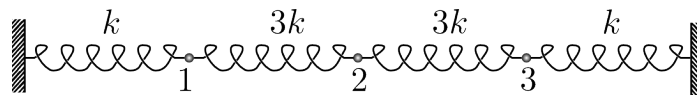

Problem 155. *1993-Fall-CM-G-3.jpg* ID:CM-G-578

A uniform smooth rod AB , of mass M hangs from two fixed supports C and D by light inextensible strings AC and BD each of length l , as shown in the figure. The rod is horizontal and $AB = CD = L \gg l$. A bead of mass m is located at the center of the rod and can slide freely on the rod. Let θ be the inclination of the strings to the vertical, and let x be the distance of the bead from the end of the rod (A). The initial condition is $\theta = \alpha < \pi/2$, $\dot{\theta} = 0$, $x = L/2$, and $\dot{x} = 0$. Assume the system moves in the plane of the figure.

1. Obtain the Lagrangian $\mathcal{L} = \mathcal{L}(\theta, \dot{\theta}, x, \dot{x})$ and write down the Lagrange's equations of motion for x and θ .
2. Obtain the first integrals of the Lagrange's equations of the motion for x and θ subject to the initial condition.
3. Find the speeds of the bead and the rod at $\theta = 0$.

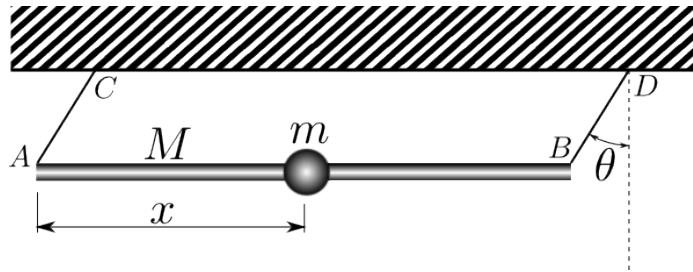
**Problem 156.** *1993-Spring-CM-G-4.jpg* ID:CM-G-597

Because of the gravitational attraction of the earth, the cross section for collisions with incident asteroids or comets is larger than πR_e^2 where R_e is the physical radius of the earth.

1. Write the Lagrangian and derive the equations of motion for an incident object of mass m . (For simplicity neglect the gravitational fields of the sun and the other planets and assume that the mass of the earth, M is much larger than m .)
2. Calculate the effective collisional radius of the earth, R , for an impact by an incident body with mass, m , and initial velocity v , as shown, starting at a point far from the earth where the earth's gravitational field is negligibly small. Sketch the paths of the incident body if it starts from a point 1) with $b < R_e$ 2) with $b \gg R_e$, and 3) at the critical distance R . (Here b is the impact parameter.)
3. What is the value of R if the initial velocity relative to the earth is $v = 0$? What is the probability of impact in this case?

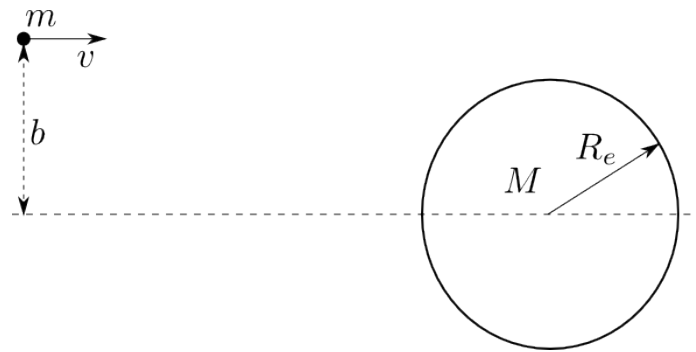

Problem 157. 1993-Spring-CM-G-5

ID:CM-G-616

Consider a particle of mass m constrained to move on the surface of a cone of half angle β , subject to a gravitational force in the negative z -direction. (See figure.)

1. Construct the Lagrangian in terms of two generalized coordinates and their time derivatives.
2. Calculate the equations of motion for the particle.
3. Show that the Lagrangian is invariant under rotations around the z -axis, and, calculate the corresponding conserved quantity.

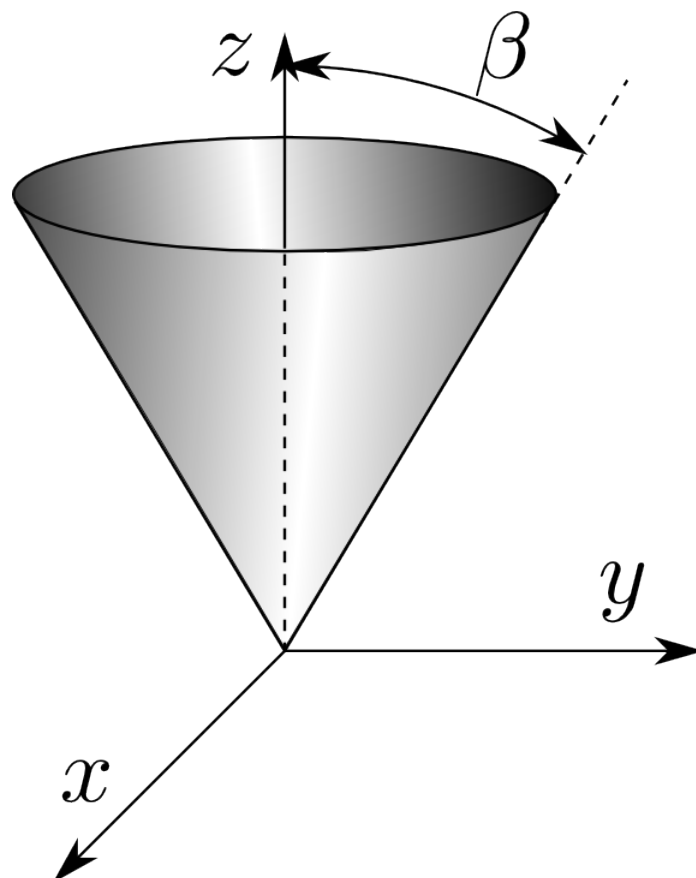

Problem 158. *1994-Fall-CM-G-1.jpg* ID:CM-G-635

Solve for the motion of the vector $\vec{M} = \vec{r} \times \vec{P}$, where \vec{P} is the generalized momentum, for the case when the Hamiltonian is $\mathcal{H} = -\gamma \vec{M} \cdot \vec{H} + P^2/2m$, where γ and \vec{H} are constant. Describe your solution.

Problem 159. *1994-Fall-CM-G-2.jpg* ID:CM-G-641

A particle is constrained to move on the frictionless surface of a sphere of radius R in a uniform gravitational field of strength g .

1. Find the equations of motion for this particle.
2. Find the motion in orbits that differ from horizontal circles by small non-vanishing amounts. In particular, find the frequencies in both azimuth ϕ and co-latitude θ . Are these orbits closed? (ϕ and θ are the usual spherical angles when the positive z axis is oriented in the direction of the gravitational field \vec{g} .)
3. Suppose the particle to be moving in a circular orbit with kinetic energy T_0 . If the strength g of the gravitational field is slowly and smoothly increased until it, reaches the value g_1 , what is the new value of the kinetic energy?

Problem 160. *1994-Fall-CM-G-3.jpg* ID:CM-G-654

A particle of mass m moves under the influence of an attractive central force $F(r) = -k/r^3$, $k > 0$. Far from the center of force, the particle has a kinetic energy E .

1. Find the values of the impact parameter b for which the particle reaches $r = 0$.
2. Assume that the initial conditions are such that the particle misses $r = 0$. Solve for the scattering angle θ_s , as a function of E and the impact parameter b .

Problem 161. *1994-Spring-CM-G-1.jpg* ID:CM-G-667

A bead slides without friction on a stiff wire of shape $r(z) = az^n$, with $z > 0$, $0 < n < 1$, which rotates about the vertical z axis with angular frequency ω , as shown in the figure.

1. Derive the Lagrange equation of motion for the bead.
2. If the bead follows a horizontal circular trajectory, find the height z_0 in terms of n , a , ω , and the gravitational acceleration g .
3. Find the conditions for stability of such circular trajectories.
4. For a trajectory with small oscillations in the vertical direction, find the angular frequency of the oscillations, ω' , in terms of n , a , z_0 , and ω .
5. What conditions are required for closed trajectories of the bead?

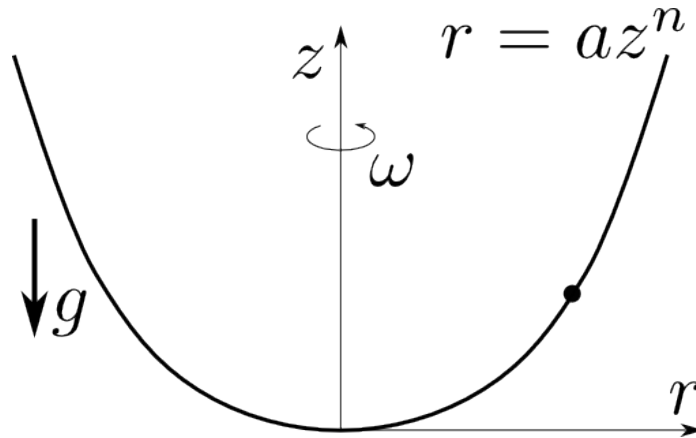

Problem 162. *1994-Spring-CM-G-2.jpg*

ID:CM-G-689

Consider two point particles each of mass m , sliding on a circular ring of radius R . They are connected by springs of spring constant k which also slide on the ring. The equilibrium length of each spring is half the circumference of the ring. Ignore gravity and friction.

1. Write down the Lagrangian of the system with the angular positions of the two particles as coordinates. (assume only motions for which the two mass points do not meet or pass.)
2. By a change of variables reduce this, essentially, to a one-body problem. Plus what?
3. Write down the resulting equation of motion and give the form of the general solution.

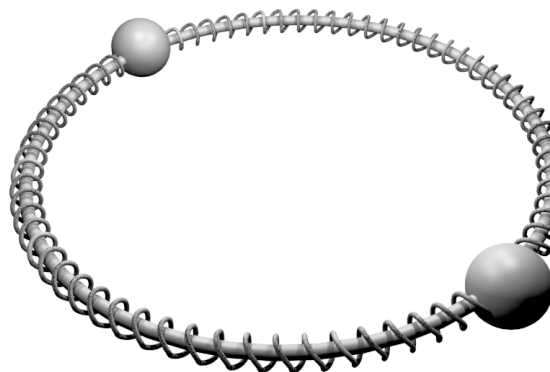

Problem 163. *1994-Spring-CM-G-3.jpg*

ID:CM-G-709

A simple pendulum of length l and mass m is attached to a block of mass M , which is free to slide without friction in a horizontal direction. All motion is confined to a plane. The pendulum is displaced by a small angle θ_0 and released.

1. Choose a convenient set of generalized coordinates and obtain Lagrange's equations of motion. What are the constants of motion?
2. Make the small angle approximation ($\sin \theta \approx \theta$, $\cos \theta \approx 1$) and solve the equations of motion. What is the frequency of oscillation of the pendulum, and what is the magnitude of the maximum displacement of the block from its initial position?

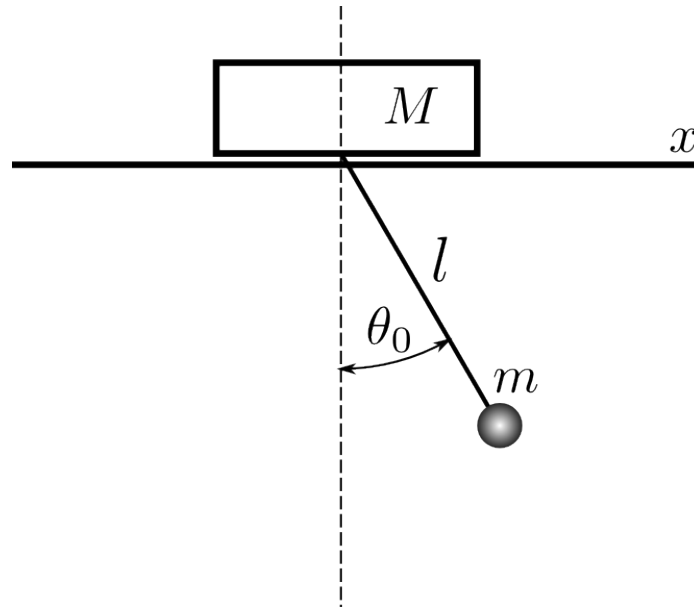

Problem 164. *1995-Fall-CM-G-1.jpg*

ID:CM-G-725

Consider a system of two point-like weights, each of mass M , connected by a massless rigid rod of length l . The upper weight slides on a horizontal frictionless rail and is connected to a horizontal spring, with spring constant k , whose other end is fixed to a wall as shown below. The lower weight swings on the rod, attached to the upper weight and its motion is confined to the vertical plane.

1. Find the exact equations of motion of the system.
2. Find the frequencies of small amplitude oscillation of the system.
3. Describe qualitatively the modes of small oscillations associated with the frequencies you found in the previous part.

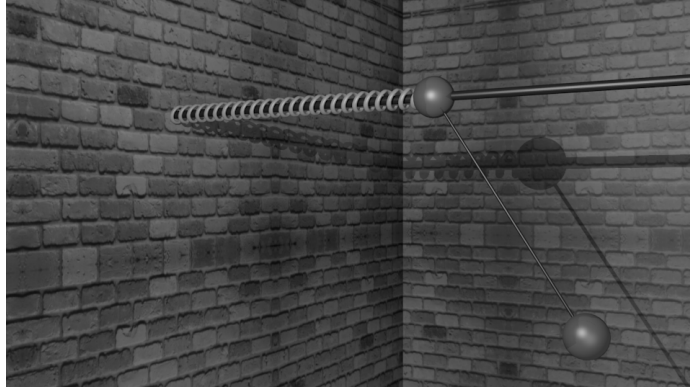
**Problem 165.** 1995-Fall-CM-G-2

ID:CM-G-743

A gyrocompass is located at a latitude β . It is built of a spherical gyroscope (moment of inertia I) whose rotation axis is constrained to the plane tangent to Earth as shown in the figure. Let the deflection of the gyro's axis eastward from the north be denoted by ϕ and the angle around its rotation axis by θ . Angular frequency of earth's rotation is ω_E .

1. Write the components of the total angular velocity $\vec{\Omega}$ of the gyro in the reference frame of the principal axes of its moment of inertia attached to the gyro.
2. Write the Lagrangian $L(\phi, \dot{\phi}, \theta, \dot{\theta})$ for the rotation of the gyrocompass.
3. Write the exact equations of motion and solve them for $\phi \ll 1$. (Hint: You may use Euler-Lagrange equations, or Euler's dynamical equations for rigid body rotation)
4. Calculate the torque that must be exerted on the gyro to keep it in the plane.

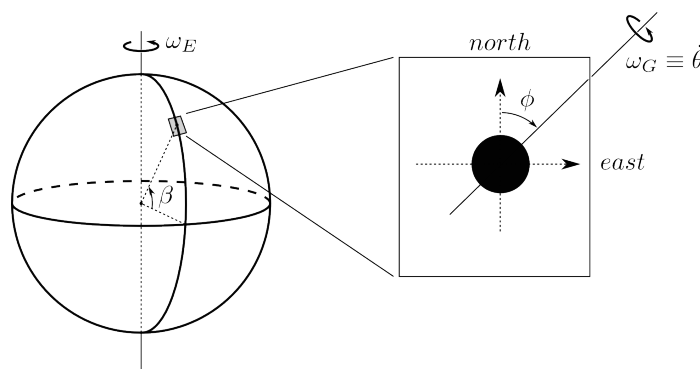
**Problem 166.** 1995-Fall-CM-G-3.jpg

ID:CM-G-763

Find the curve joining two points, along which a particle falling from rest under the influence of gravity travels from the higher to the lower point in the least time. Assume that there is no friction. (Hint: Solve for the horizontal coordinate y as a function of the vertical coordinate x .)

Problem 167. *1995-Spring-CM-G-1*

ID:CM-G-769

Two masses M and m are connected through a small hole in a vertical wall by an arbitrarily (infinitely) long massless rope, as shown in the figure. The mass M is constrained to move along the vertical line, while the mass m is constrained to move along one side of the wall. Energy is conserved at all times. The (vertical) gravitational acceleration is g . You are required to:

1. Construct the Lagrangian and the second order equations of motion in the variables (r, θ) .
2. The general solution of these equations of motion is very complicated. However, you are asked to determine only those solutions of the equations of motion for which the angular momentum of the mass m is constant. Comment on any additional information you may need in order to complete these solutions for all times. Given the initial condition $r_0 = A$, $\theta_0 = \pi$, $\dot{r}_0 = 0$, and $\dot{\theta}_0 = 0$, determine the motion of the mass m assuming that at $r = 0$ its momentum
 - (a) reverses itself or
 - (b) remains unchanged. How does the nature of the motion in this case depend on the mass ratio $\mu \equiv M/m$?

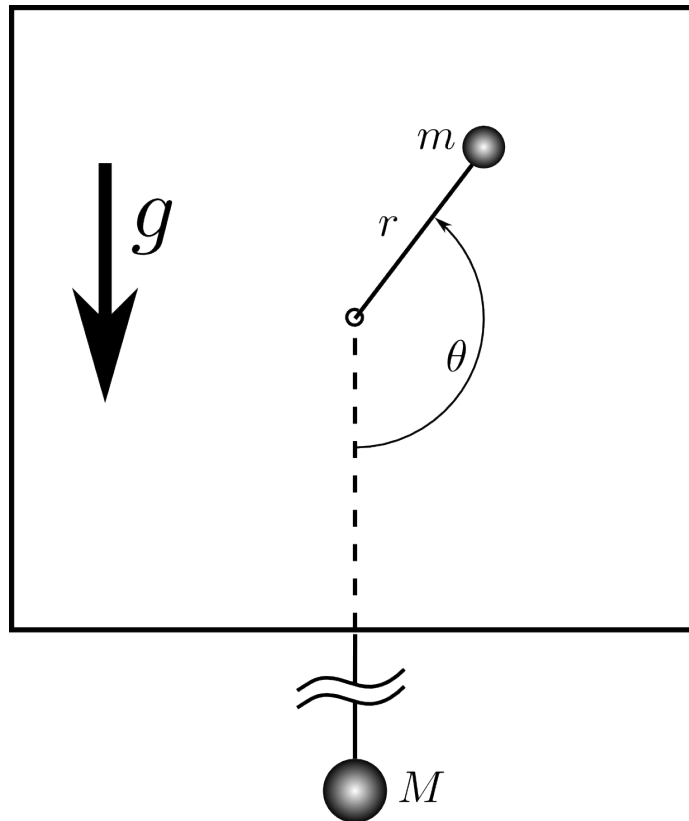

Problem 168. *1995-Spring-CM-G-2*

ID:CM-G-790

A particle of mass m moves under the influence of a central attractive force

$$F = -\frac{k}{r^2}e^{-r/a}$$

1. Determine the condition on the constant a such that circular motion of a given radius r_0 will be stable.
2. Compute the frequency of small oscillations about such a stable circular motion.

Problem 169. *1995-Spring-CM-G-3*

ID:CM-G-805

A soap film is stretched over 2 coaxial circular loops of radius R , separated by a distance $2H$. Surface tension (energy per unit area, or force per unit length) in the film is $\tau = \text{const}$. Gravity is neglected.

1. Assuming that the soap film takes an axisymmetric shape, such as illustrated in the figure, find the equation for $r(z)$ of the soap film, with r_0 (shown in the figure) as the only parameter. (Hint: You may use either variational calculus or a simple balance of forces to get a differential equation for $r(z)$).
2. Write a transcendental equation relating r_0 , R and H , determine approximately and graphically the maximum ratio $(H/R)_c$, for which a solution of the first part exists. If you find that multiple solutions exist when $H/R < (H/R)_c$, use a good physical argument to pick out the physically acceptable one.
3. What shape does the soap film assume for $H/R > (H/R)_c$?

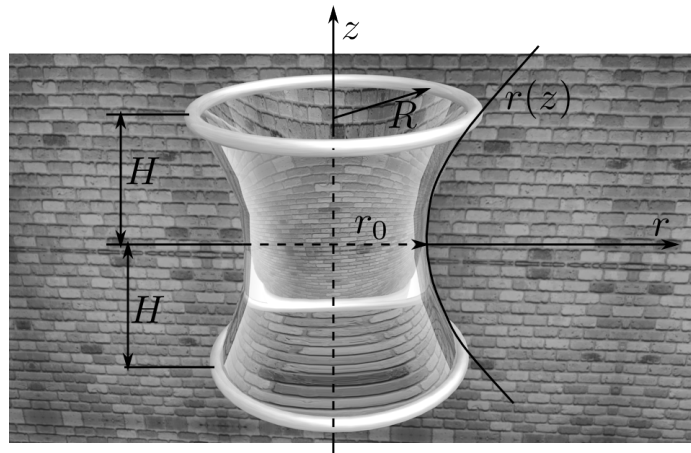
**Problem 170.** *May the Force be with you*

ID:CM-G-806

A soap film is stretched over 2 coaxial circular loops of radius R , separated by a distance $2H$. Surface tension (energy per unit area, or force per unit length) in the film is $\tau = \text{const}$. Gravity is neglected.

1. Assuming that the soap film takes an axisymmetric shape, such as illustrated in the figure, find the equation for $r(z)$ of the soap film, with r_0 (shown in the figure) as the only parameter. (Hint: You may use either variational calculus or a simple balance of forces to get a differential equation for $r(z)$).
2. Write a transcendental equation relating r_0 , R and H , determine approximately and graphically the maximum ratio $(H/R)_c$, for which a solution of the first part exists. If you find that multiple solutions exist when $H/R < (H/R)_c$, use a good physical argument to pick out the physically acceptable one.
3. Compute the force required to hold the loops apart at distance $2H$.

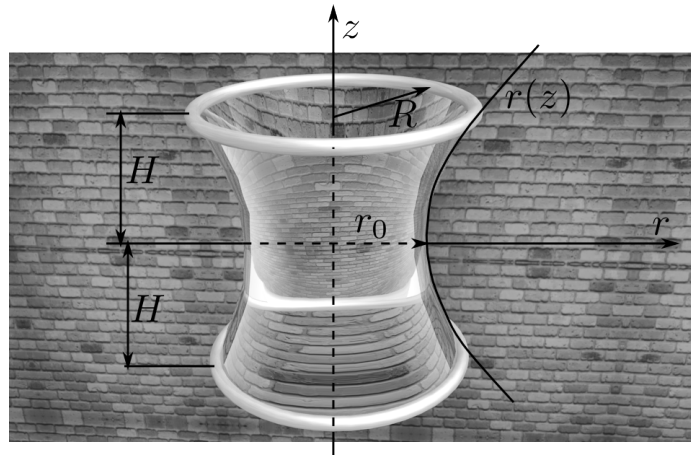
**Problem 171.** 1996-Fall-CM-G-4

ID:CM-G-825

A particle of mass m slides inside a smooth hemispherical cup under the influence of gravity, as illustrated. The cup has radius a . The particle's angular position is determined by polar angle θ (measured from the negative vertical axis) and azimuthal angle ϕ .

1. Write down the Lagrangian for the particle and identify two conserved quantities.
2. Find a solution where $\theta = \theta_0$ is constant and determine the angular frequency $\dot{\phi} = \omega_0$ for the motion.
3. Now suppose that the particle is disturbed slightly so that $\theta = \theta_0 + \alpha$ and $\omega = \omega_0 + \beta$, where α and β are small time-dependent quantities. Find the frequency of the small oscillation in θ that the particle undergoes.

Hint: Follow the standard route: Find the equation of motion for θ . Find conserving quantities, energy and angular momentum. Exclude the angular momentum from the equation of motion and get the effective potential for θ . Check that for equilibrium, the value of θ coincides with the one following from the elementary physics. Expand the potential, and find the frequency of oscillations in the effective potential.

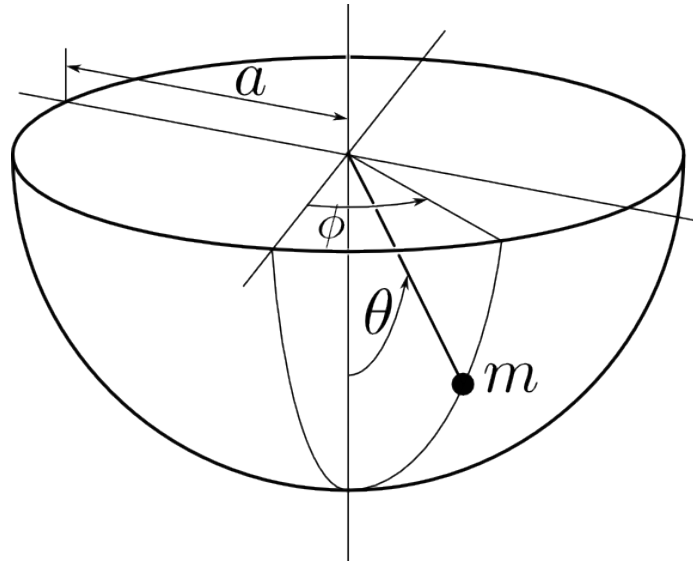

Problem 172. 1996-Fall-CM-G-5

ID:CM-G-842

A particle of mass m moves under the influence of a central force given by

$$\vec{F} = -\frac{\alpha}{r^2}\hat{r} - \frac{\beta}{mr^3}\hat{r},$$

where α and β are real, positive constants.

1. For what values of orbital angular momentum L are circular orbits possible?
2. Find the angular frequency of small radial oscillations about these circular orbits.
3. In the case of $L = 2$ units of angular momentum, for what value (or values) of β is the orbit with small radial oscillations closed?

Problem 173. 1996-Spring-CM-G-1.jpg

ID:CM-G-860

A particle of mass m moves under the influence of a central force with potential

$$V(r) = \alpha \log(r), \quad \alpha > 0.$$

1. For a given angular momentum L , find the radius of the circular orbit.
2. Find the angular frequency of small radial oscillations about this circular orbit.
3. Is the resulting orbit closed? Reason.

Problem 174. *1996-Spring-CM-G-3.jpg*

ID:CM-G-880

A hoop of mass m and radius R rolls without slipping down an inclined plane of mass M and angle of incline α . The inclined plane is resting on a frictionless, horizontal surface. The system is at rest at $t = 0$ with the hoop making contact at the very top of the incline. The initial position of the inclined plane is $X(0) = X_0$ as shown in the figure.

1. Find Lagrange's equations for this system.
2. Determine the position of the hoop, $x(t)$, and the plane, $X(t)$, after the system is released at $t = 0$.

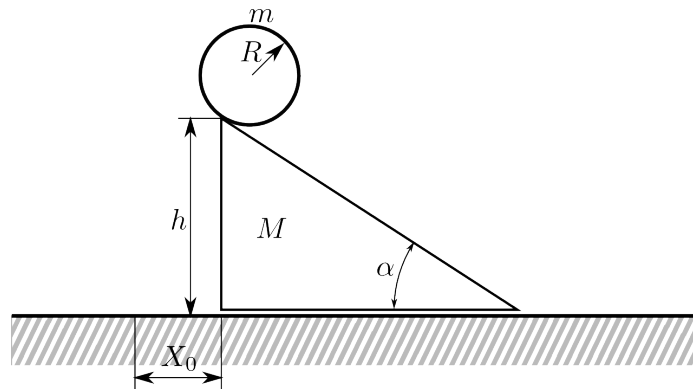
**Problem 175.** *1997-Fall-CM-G-4.jpg*

ID:CM-G-895

Consider two identical “dumbbells”, as illustrated below. Initially the springs are unstretched, the left dumbbell is moving with velocity v_0 , and the right dumbbell is at rest. The left dumbbell then collides elastically with the right dumbbell at time $t = t_0$. The system is essentially one-dimensional.

1. Qualitatively trace the time-evolution of the system, indicating the internal and centers-of-mass motions.
2. Find the maximal compressions of the springs.
3. Give the time at which the maximal spring-compressions occur, and any other relevant times.

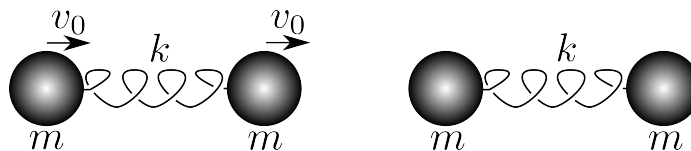

Problem 176. *1997-Fall-CM-G-5.jpg* ID:CM-G-912

Two simple pendula of equal length l and equal mass m are connected by a spring of force-constant k , as shown in the sketch below.

1. Find the eigenfrequencies of motion for small oscillations of the system when the force $F = 0$.
2. Derive the time dependence of the angular displacements $\theta_1(t)$ and $\theta_2(t)$ of both pendula if a force $F = F_0 \cos \omega t$ acts on the left pendulum only, and ω is not equal to either of the eigenfrequencies. The initial conditions are $\theta_1(0) = \theta_0$, $\theta_2(0) = 0$, and $\dot{\theta}_1(0) = \dot{\theta}_2(0) = 0$, where $\dot{\theta} \equiv d\theta/dt$. (Note that there are no dissipative forces acting.)

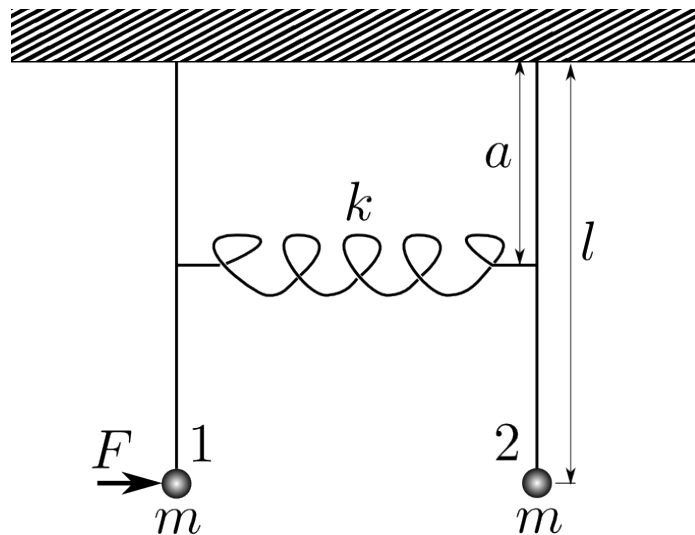
**Problem 177.** *1997-Spring-CM-G-4.jpg* ID:CM-G-928

The curve illustrated below is a parametric two dimensional curve (not a three dimensional helix). Its coordinates $x(\tau)$ and $y(\tau)$ are

$$\begin{aligned} x &= a \sin(\tau) + b\tau \\ y &= -a \cos(\tau), \end{aligned}$$

where a and b are constant, with $a > b$. A particle of mass m slides without friction on the curve. Assume that gravity acts vertically, giving the particle the potential energy $V = mgy$.

1. Write down the Lagrangian for the particle on the curve in terms of the single generalized coordinate τ .
2. From the Lagrangian, find p_τ , the generalized momentum corresponding to the parameter τ .
3. Find the Hamiltonian in terms of the generalized coordinate and momentum.

4. Find the two Hamiltonian equations of motion for the particle from your Hamiltonian.

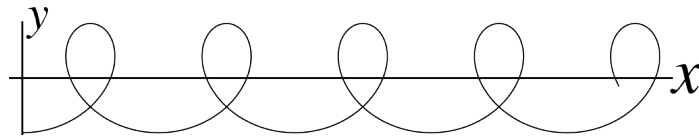

Problem 178. *1997-Spring-CM-G-5.jpg*

ID:CM-G-953

The illustrated system consists of rings of mass m which slide without friction on vertical rods with uniform spacing d . The rings are connected by identical massless springs which have tension T , taken to be constant for small ring displacements. Assume that the system is very long in both directions.

1. Write down an equation of motion for the vertical displacement q_i of the i^{th} ring, assuming that the displacements are small.
2. Solve for traveling wave solutions for this system; find the limiting wave velocity as the wave frequency tends toward zero.

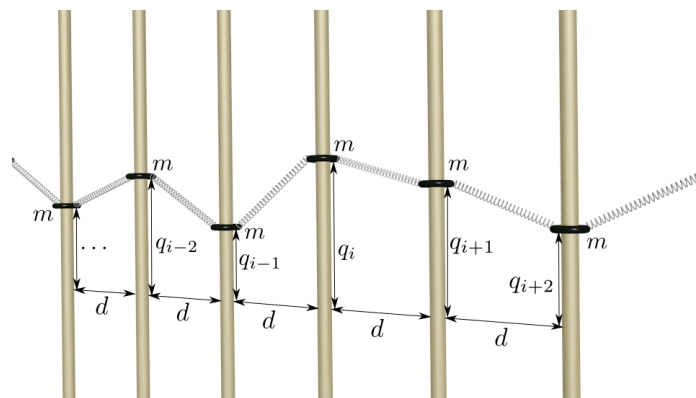

Problem 179. *1998-Fall-CM-G-4.jpg*

ID:CM-G-971

1. For relativistic particles give a formula for the relationship between the total energy E , momentum P , rest mass m_0 , and c , the velocity of light.
2. A particle of mass M , initially at rest, decays into two particles of rest masses m_1 and m_2 . What is the final total energy of the particle m_1 after the decay? Note: make no assumptions about the relative magnitudes of m_1 , m_2 , and M other than $0 \leq m_1 + m_2 < M$.
3. Now assume that a particle of mass M , initially at rest, decays into three particles of rest masses m_1 , m_2 , and m_3 . Use your result from the previous part to determine the maximum possible total energy of the particle m_1 after the decay. Again, make no assumptions about the relative magnitudes of m_1 , m_2 , m_3 , and M other than $0 \leq m_1 + m_2 + m_3 < M$.

Problem 180. *1998-Fall-CM-G-5.jpg* ID:CM-G-984

Two hard, smooth identical billiard balls collide on a tabletop. Ball A is moving initially with velocity v_0 , while rolling without slipping. Ball B is initially stationary. During the elastic collision, friction between the two balls and with the tabletop can be neglected, so that no rotation is transferred from ball A to ball B, and both balls are sliding immediately after the collision. Ball A is also rotating. Both balls have the same mass.

Data: Solid sphere principal moment of inertia = $(2/5)MR^2$.

1. If ball B leaves the collision at angle θ from the initial path of ball A, find the speed of ball B, and the speed and direction of ball A, immediately after the collision.
2. Assume a kinetic coefficient of friction μ between the billiard balls and the table (and gravity acts with acceleration g). Find the time required for ball B to stop sliding, and its final speed.
3. Find the direction and magnitude of the friction force on ball A immediately after the collision.

Problem 181. *1998-Spring-CM-G-4.jpg* ID:CM-G-1002

A mass m moves on a smooth, frictionless horizontal table. It is attached by a massless string of constant length $l = 2\pi a$ to a point Q_0 of an immobile cylinder. At time $t_0 = 0$ the mass at point P is given an initial velocity v_0 at right angle to the extended string, so that it wraps around the cylinder. At a later time t , the mass has moved so that the contact point Q with the cylinder has moved through an angle θ , as shown. The mass finally reaches point Q_0 at time t_f .

1. Is kinetic energy constant? Why or why not?
2. Is the angular momentum about O , the center of the cylinder, conserved? Why or why not?
3. Calculate as a function of θ , the speed of the contact point Q , as it moves around the cylinder. Then calculate the time it takes mass m to move from point P to point Q_0 .
4. Calculate the tension T in the string as a function of m , v , θ , and a .
5. By integrating the torque due to T about O over the time it takes mass m to move from point P to point Q_0 , show that the mass's initial angular momentum mv_0l is reduced to zero when the mass reaches point Q_0 . Hint: evaluate

$$\int_0^{t_f} \Gamma dt = \int_0^{2\pi} \frac{\Gamma}{d\theta/dt} d\theta.$$

6. What is the velocity (direction and magnitude) of m when it hits Q_0 ?

7. What is the tension T when the mass hits Q_0 ?

You may wish to use the (x, y) coordinate system shown.

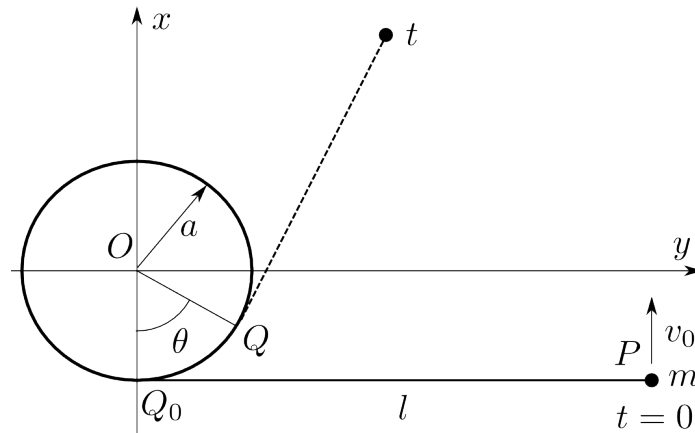

Problem 182. 1998-Spring-CM-G-5.jpg

ID:CM-G-1035

A mass m is attached to the top of a slender massless stick of length l . The stick stands vertically on a rough ramp inclined at an angle of 45° to the horizontal. The static coefficient of friction between the tip of the stick and the ramp is precisely 1 so the mass + stick will just balance vertically, in unstable equilibrium, on the ramp. Assume normal gravitational acceleration, g , in the downward direction. The mass is given a slight push to the right, so that the mass + stick begins to fall to the right.

1. When the stick is inclined at an angle θ to the vertical, as illustrated below, then what are the components of mg directed along the stick and perpendicular to the stick?
2. If the stick does not slip, then what is the net force exerted upward by the ramp on the lower tip of the stick? (Hint: Use conservation of energy to determine the radial acceleration of the mass.)
3. Can the ramp indeed exert this force? (Hint: Consider the components normal and perpendicular to the ramp.)
4. At what angle θ does the ramp cease to exert a force on the stick?

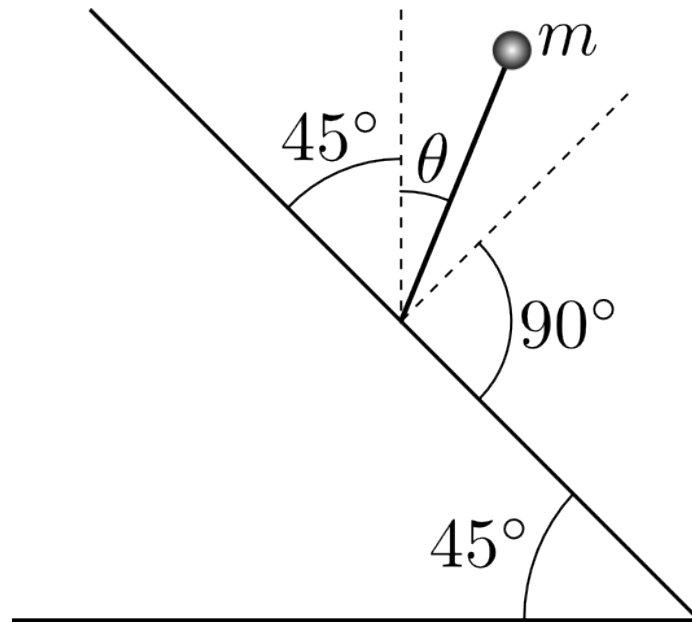

Problem 183. *1999-Fall-CM-G-4.jpg*

ID:CM-G-1055

A small satellite, which you may assume to be massless, carries two hollow antennae, each of mass m and length $2R$, lying one within the other as shown in Fig. A below. The far ends of the two antennae are connected by a massless spring of strength constant k and natural length $2R$. The satellite and the two antennae are spinning about their common center with an initial angular speed ω_0 . A massless motor forces the two antennae to extend radially outward from the satellite, symmetrically in opposite directions, at constant speed v_0 .

1. Set up the Lagrangian for the system and find the equations of motion.
2. Show that it is possible to choose k so that no net work is done by the motor that drives out the antennae, while moving the two antennae from their initial position to their final fully extended position shown in Fig. B below. Determine this value of k .

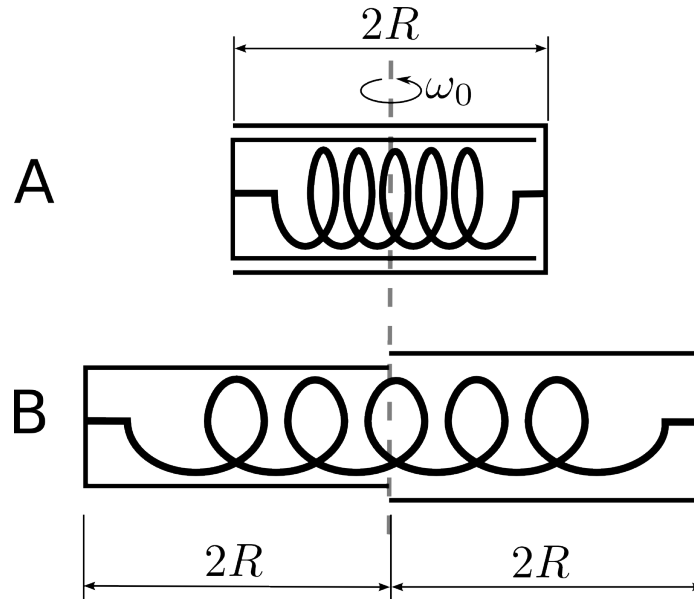

Problem 184. 1999-Fall-CM-G-5.jpg

ID:CM-G-1072

A one-dimensional coupled oscillator system is constructed as illustrated: the three ideal, massless springs have equal spring constants k , the two masses m are equal, and the system is assembled so that it is in equilibrium when the springs are unstretched. The masses are constrained to move along the axis of the springs only. An external oscillating force acting along the axis of the springs and with a magnitude $\Re(Fe^{i\omega t})$ is applied to the left mass, with F a constant, while the right mass experiences no external force.

1. Solve first for the unforced ($F = 0$) behavior of the system: set up the equations of motion and solve for the two normal mode eigenvectors and frequencies.
2. Now find the steady-state oscillation at frequency ω vs. time for the forced oscillations. Do this for each of the two masses, as a function of the applied frequency ω and the force constant F .
3. For one specific frequency, there is a solution to the previous part for which the left mass does not move. Specify this frequency and give a simple physical explanation of the motion in this special case that would make the frequency, the external oscillating force, and the motion as a whole understandable to a freshman undergraduate mechanics student.

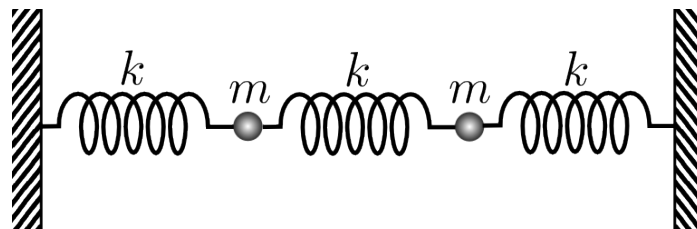

Problem 185. *1999-Spring-CM-G-4.jpg*

ID:CM-G-1092

A particle of mass m is observed to move in a central field following a planar orbit (in the $x - y$ plane) given by.

$$r = r_0 e^{-\theta},$$

where r and θ are coordinates of the particle in a polar coordinate system.

1. Prove that, at any instant in time, the particle trajectory is at an angle of 45° to the radial vector.
2. When the particle is at $r = r_0$ it is seen to have an angular velocity $\Omega > 0$. Find the total energy of the particle and the potential energy function $V(r)$, assuming that $V \rightarrow 0$ as $r \rightarrow +\infty$.
3. Determine how long it will take the particle to spiral in from $r = r_0$, to $r = 0$.

Problem 186. *2000-Fall-CM-G-4.jpg*

ID:CM-G-1111

Consider the motion of a rigid body. \hat{x} - \hat{y} - \hat{z} describe a right-handed coordinate system that is fixed in the rigid body frame and has its origin at the center-of-mass of the body. Furthermore, the axes are oriented so that the inertial tensor is diagonal in the \hat{x} - \hat{y} - \hat{z} frame:

$$I = \begin{pmatrix} I_x & 0 & 0 \\ 0 & I_y & 0 \\ 0 & 0 & I_z \end{pmatrix}.$$

The angular velocity of the rigid body is given by.

$$\vec{\omega} = \omega_x \hat{x} + \omega_y \hat{y} + \omega_z \hat{z}$$

1. Give the equations that describe the time-dependence of $\vec{\omega}$ when the rigid body is subjected to an arbitrary torque.
2. Prove the "Tennis Racket Theorem": if the rigid body is undergoing torque-free motion and its moments of inertia obey $I_x < I_y < I_z$, then:
 - (a) rotations about the x -axis are stable, and
 - (b) rotations about the z -axis are stable, but
 - (c) rotations about the y -axis are unstable.

Note: By "stable about the x -axis", we mean that, if at $t = 0$, $\omega_y \ll \omega_x$ and $\omega_z \ll \omega_x$, then this condition will also be obeyed at any later time.

Problem 187. *2000-Fall-CM-G-5.jpg*

ID:CM-G-1147

Particles are scattered classically by a potential:

$$V(r) = \begin{cases} U(1 - r^2/a^2), & \text{for } r \leq a \\ 0, & \text{for } r > a \end{cases}, \quad U \text{ is a constant.}$$

Assume that $U > 0$. A particle of mass m is coming in from the left with initial velocity v_0 and impact parameter $b < a$. Hint: work in coordinates (x, y) not (r, ϕ) .

1. What are the equations of motion for determining the trajectory $x(t)$ and $y(t)$ when $r < a$?
2. Assume that at $t = 0$ the particle is at the boundary of the potential $r = a$. Solve your equations from the previous part to find the trajectory $x(t)$ and $y(t)$ for the time period when $r < a$. Express your answer in terms of sinh and cosh functions.
3. For initial energy $\frac{1}{2}mv_0^2 = U$, find the scattering angle θ as function of b .

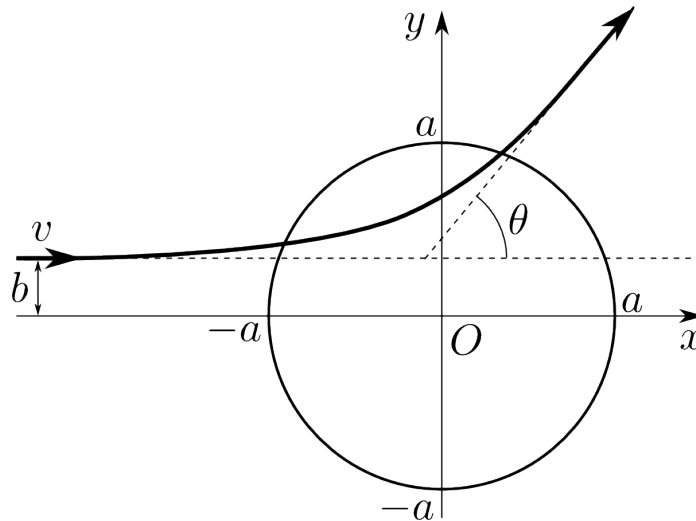
**Problem 188.** *2001-Fall-CM-G-4.jpg*

ID:CM-G-1174

A rigid rod of length a and mass m is suspended by equal massless threads of length L fastened to its ends. While hanging at rest, it receives a small impulse $\vec{J} = J_0\hat{y}$ at one end, in a direction perpendicular to the axis of the rod and to the thread. It then undergoes a small oscillation in the $x - y$ plane. Calculate the normal frequencies and the amplitudes of the associated normal modes in the subsequent motion.

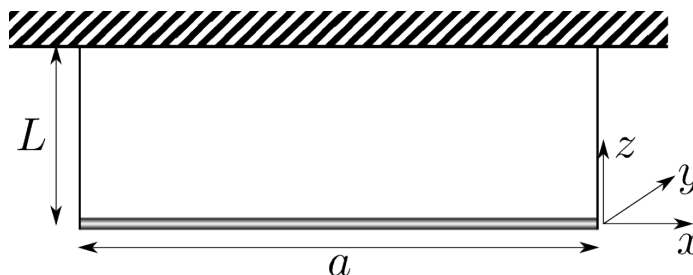

Problem 189. *2001-Fall-CM-G-5.jpg* ID:CM-G-1186

A uniform, solid sphere (mass m , radius R , moment of inertia $I = \frac{2}{5}mR^2$) sits on a uniform, solid block of mass m (same mass as the solid sphere). The block is cut in the shape of a right triangle, so that it forms an inclined plane at an angle θ , as shown. Initially, both the sphere and the block are at rest. The block is free to slide without friction on the horizontal surface shown. The solid sphere rolls down the inclined plane without slipping. Gravity acts uniformly downward, with acceleration g . Take the x and y axes to be horizontal and vertical, respectively, as shown in the figure.

1. Find the x and y components of the contact force between the solid sphere and the block, expressed in terms of m , g , and θ .
2. The solid sphere starts at the top of the inclined plane, tangent to the inclined surface, as shown. If θ is too large, the block will tip. Find the maximum angle θ_{max} that will permit the block to start sliding without tipping.

Reminder: A uniform right triangle, such as the one shown in the figure, has its center of mass located $1/3$ of the way up from the base and $1/3$ of the way over from the left edge.

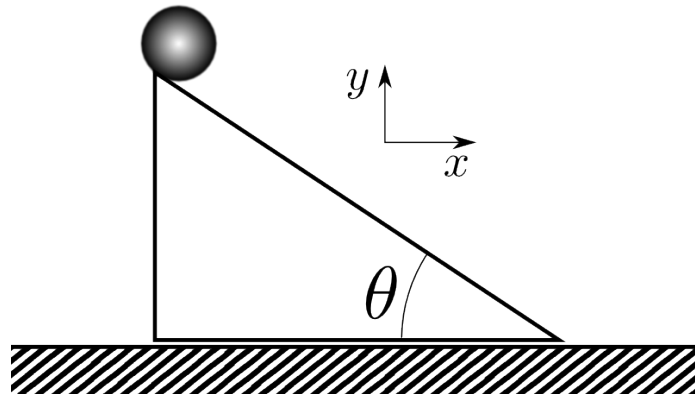
**Problem 190.** *2001-Spring-CM-G-4.jpg* ID:CM-G-1204

A rotor consists of two square flat masses: m and $2m$ as indicated. These masses are glued so as to be perpendicular to each other and rotated about a axis bisecting their common edge such that $\vec{\omega}$ points in the $x - z$ plane 45° from each axis. Assume there is no gravity.

1. Find the principal moments of inertia for this rotor, I_{xx} , I_{yy} , and I_{zz} . Note that off-diagonal elements vanish, so that x , y , and z are principal axes.
2. Find the angular momentum, \vec{L} and its direction.
3. What torque vector $\vec{\tau}$ is needed to keep this rotation axis fixed in time?

Give all vectors in components of the internal $x - y - z$ system of coordinates.

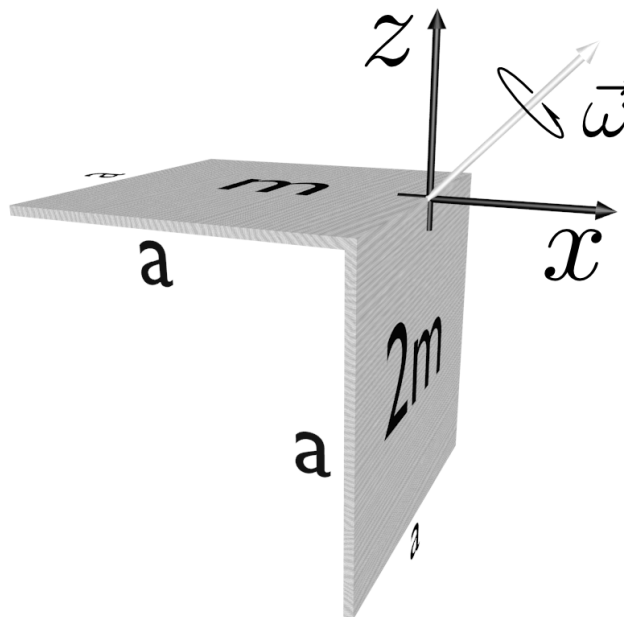
**Problem 191.** *2001-Spring-CM-G-5*

ID:CM-G-1225

An ideal massless spring hangs vertically from a fixed horizontal support. A block of mass m rests on the bottom of a box of mass M and this system of masses is hung on the spring and allowed to come to rest in equilibrium under the force of gravity. In this condition of equilibrium the extension of the spring beyond its relaxed length is Δy . The coordinate y as shown in the figure measures the displacement of M and m from equilibrium.

1. Suppose the system of two masses is raised to a position $y = -d$ and released from rest at $t = 0$. Find an expression for $y(t)$ which correctly describes the motion for $t \geq 0$.
2. For the motion described in the previous part, determine an expression for the force of M on m as a function of time.
3. For what value of d is the force on m by M instantaneously zero immediately after m and M are released from rest at $y = -d$?

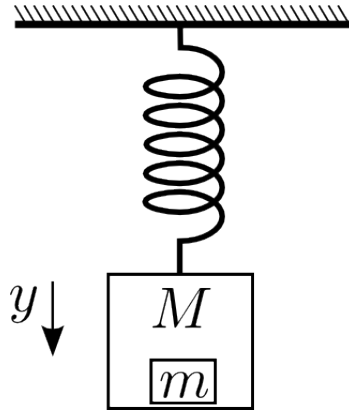

Problem 192. *A string with a tension* ID:CM-G-1235

A string of tension T and linear mass density ρ connects two horizontal points distance L apart from each other. y is the vertical coordinate pointing up, and x the is horizontal coordinate.

1. Write down the functional of potential energy of the string vs. the shape of the string $y(x)$. Specify the boundary conditions for the function $y(x)$.
2. Write down the equation which gives the shape of minimal energy for the string.
3. Find the solution of the differential equation which satisfies the boundary conditions. (Do not try to solve the transcendental equation for one of the constant. Just write it down.)
4. In the case $T \gg \rho gL$, the shape is approximately given by $y \approx -\frac{\alpha}{2}x(L - x)$. Find α .

Problem 193. *Noether's theorem* ID:CM-G-1245

Which components (or their combinations) of momentum \vec{P} and angular momentum \vec{M} are conserved in motion in the following fields.

1. the field of an infinite homogeneous plane,
2. that of an infinite homogeneous cylinder,
3. that of an infinite homogeneous prism,
4. that of two points,
5. that of an infinite homogeneous half plane,
6. that of a homogeneous cone,
7. that of a homogeneous circular torus,
8. that of an infinite homogeneous cylindrical helix of pitch h .

Problem 194. *Square frame.*

ID:CM-G-1250

A weightless square frame $ABCD$ with a side of length L is supported by ideal hinges H and H' by the middle of the sides AB and CD . A uniform solid disc of mass m and radius R is supported in the middle of the frame as shown on the figure. The axis of the disc is parallel to the side AB . The frame $ABCD$ is kept **horizontally** on a **horizontal** turntable by the vertical pink support S . The axis of the turntable goes through the disc's center. The disc is rotating with angular velocity ω around its axis in the direction shown in the figure. The turntable is rotating with angular velocity Ω around its axis in the direction shown in the figure. What force acts **on the pink support** S ? You need to find the magnitude and the direction of the force. Ignore the gravity.

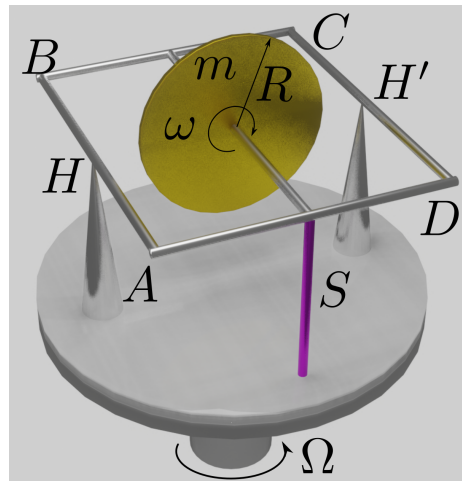

Problem 195. *Sitting comfortable on ceiling.*

ID:CM-G-1255

A weightless axis of length L of a uniform thin disc of radius R is attached to the ceiling by an ideal universal joint A (universal joint can rotate in any direction). The disc rolls on a ceiling without slipping. There is gravity g . For what minimal Ω such motion is possible?

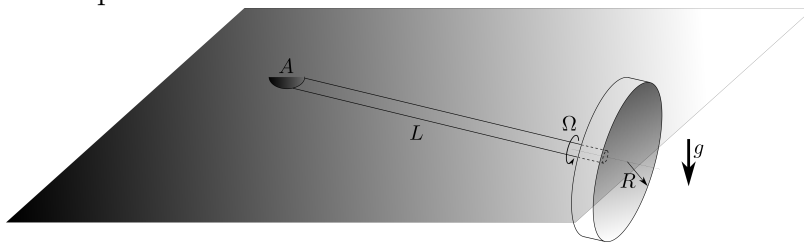

Problem 196. *Roller on a wedge.*

ID:CM-G-1260

A uniform thin disc of radius R and mass m is attached at its axis to a spring of spring coefficient k . The other end of the spring is attached at point A . The unstretched length of the spring is negligible. The disc can roll on a wedge of angle α without slipping. The point A is at distance d from the surface of the wedge, as shown. There is gravity. Find the frequency of small oscillations of the disc. The disc touches the wedge at all times.

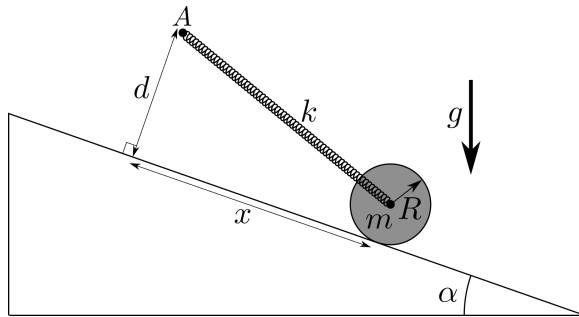

Problem 197. *Two rollers and a Pendulum.*

ID:CM-G-1265

Find eigen frequencies for the system shown on the figure. Both rollers are solid uniform discs. There is no slipping. Both disks, the platform, and the pendulum bob have the same mass m . Use $k/m = g/R = \omega_0^2$.

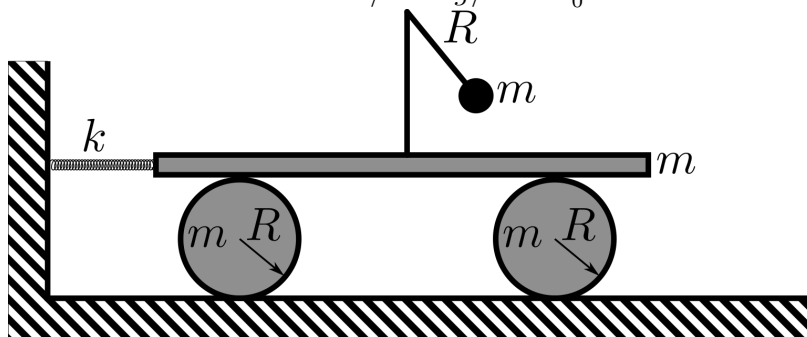

Problem 198. *Paraboloid scattering.*

ID:CM-G-1270

An immovable paraboloid (which was produced by rotating a parabola $y = \frac{x^2}{4R}$ around the y axis), elastically scatters particles that are coming from $y = -\infty$. Find the differential scattering cross-section $d\sigma$.

