

# Exam 2

**P202 Spring 2008,  
Instructor: Prof. Abanov**

**02/28/08**

Name\_\_\_\_\_

(print)

Section\_\_\_\_\_

Your grade:

### Problem 1.

A 5-A current is maintained in a simple circuit with a total resistance of  $200\ \Omega$ .

What is the potential difference across the resistance?\_\_\_\_\_

What net charge passes through any point in the circuit during a 1minute interval?\_\_\_\_\_

What net charge would pass through any point in the circuit during a 1minute interval if we doubled the resistance but kept the current constant?\_\_\_\_\_

What net charge would pass through any point in the circuit during a 1minute interval if we doubled the resistance but kept the voltage constant?\_\_\_\_\_

### Problem 2.

A battery with  $E=10V$  and internal resistance  $r=1k\Omega$  is connected to a simple circuit with a total resistance of  $R=9k\Omega$ .

What is the current through the battery?\_\_\_\_\_

What is the potential difference between the battery's terminals?\_\_\_\_\_

How much power does the battery supply to the simple circuit?\_\_\_\_\_

How much power dissipates inside the battery?\_\_\_\_\_

### Problem 3.

In the circuit shown in the picture  $E=10V$  ,  $r=1k\Omega$  ,  
 $R_1=2k\Omega$  , and  $R_2=R_3=R_4=3k\Omega$  .

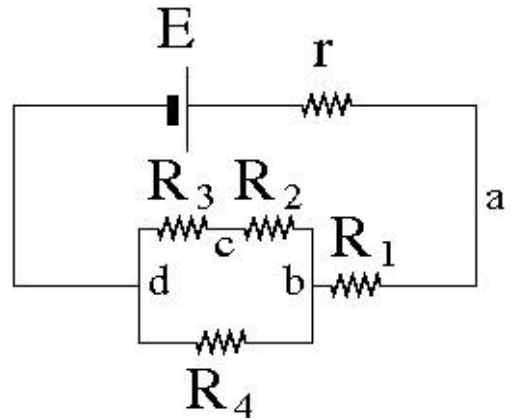

What is the current at point “a” of the circuit?\_\_\_\_\_

What is the potential difference between points “a” and “b”?\_\_\_\_\_

What is the potential difference between points “b” and “d”?\_\_\_\_\_

What is the the current at point “c”?\_\_\_\_\_

What is the potential difference between points “c” and “b”?\_\_\_\_\_

### Problem 4.

In the circuit shown in the figure  $E_1=28V$  ,  $R_2=6\Omega$  ,  
 $R_3=3\Omega$  ,  $I_2=4A$  , and  $I_3=6A$  (directions of  $I_2$  and  $I_3$  are shown)

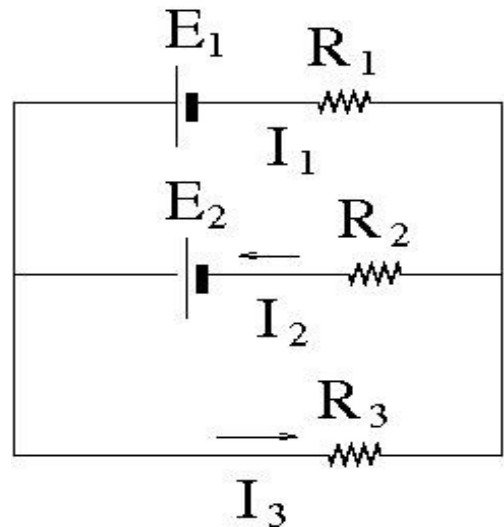

What is the magnitude and direction (show in the figure) of the current  $I_1$  ?\_\_\_\_\_

What is the value of the resistor  $R_1$  ?\_\_\_\_\_

What is  $E_2$  ?\_\_\_\_\_

### Problem 5.

An electron  $e=1.6 \times 10^{-19} \text{ C}$  ,  $m_e=9.1 \times 10^{-31} \text{ kg}$  is accelerated through a potential difference of  $2 \text{ kV}$  . It then passes into magnetic field perpendicular to its path, where it moves in a circular arc of diameter  $0.36 \text{ m}$

What is the magnitude of the velocity of the electron in magnetic field?\_\_\_\_\_

What is the magnitude of the magnetic field?\_\_\_\_\_

What is the frequency of the electron's motion in the magnetic field?\_\_\_\_\_

### Problem 6.

A metal bar is at rest on two rails, as shown on the figure.  $E=10 \text{ V}$  ,  $R=1 \Omega$  ,  $L=50 \text{ cm}$  ,  $B=5 \text{ T}$  , and  $m=0.5 \text{ kg}$

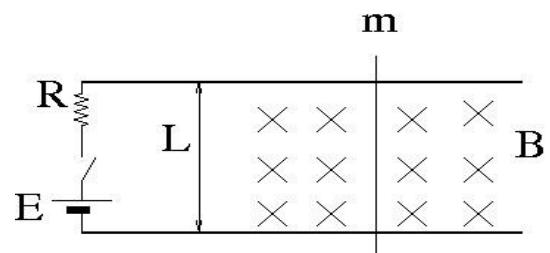

What is the current through the bar right after the switch is closed?\_\_\_\_\_

What are direction and magnitude of the magnetic force acting on the bar at the first moment?\_\_\_\_\_

What is the acceleration of the bar?\_\_\_\_\_

## Problem 7.

A planar loop of area  $A=0.05\text{m}^2$  carries a current  $I=1\text{A}$ . The magnetic field  $B=0.5\text{T}$  is at angle  $45^\circ$  with the norm to the loop.

What is magnetic moment of the loop?\_\_\_\_\_

What torque should be applied to the loop in order to keep it at rest?\_\_\_\_\_

What torque would be needed if the loop had 100 turns?

## Problem 8.

Two high current transmission lines carry currents of  $25\text{A}$  and  $75\text{A}$  in the same direction. And are suspended parallel to each other  $35\text{cm}$  apart. The vertical posts supporting these wires divide the lines into straight  $15\text{m}$  segments.

What magnetic force does each segment exert on the other?\_\_\_\_\_

Is this force attractive or repulsive?\_\_\_\_\_

What would happen to the force if we double each current?\_\_\_\_\_

### Problem 9.

A metal bar of mass  $m=10\text{kg}$  can move along two vertical straight rails which are  $L=1\text{m}$  apart from one another. The total friction force between the bar and the rails is  $F_f=50\text{N}$ . The resistor  $R=2\Omega$  connects the rails. Magnetic field is  $B=0.5\text{T}$ . After a long time the bar falls with a constant velocity.

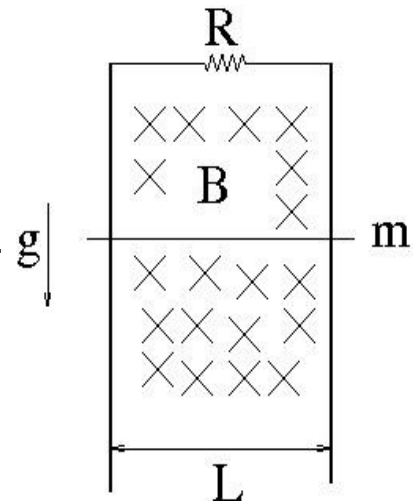

What is the direction of electric current induced by the motion?(show on the figure)

What is the direction of the magnetic force acting on the bar?(show on the figure)

What is the velocity of the bar?\_\_\_\_\_

What will be the velocity if we double the magnetic field?\_\_\_\_\_

### Problem 10.

A circuit show on the figure has  $E=10\text{V}$ ,  $R=1\text{k}\Omega$ ,  $L=5\text{mH}$ .

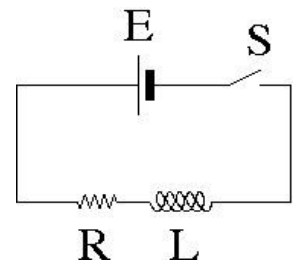

What is the current right after the switch is closed?\_\_\_\_\_

How fast the current is changing right after the switch is closed?\_\_\_\_\_

What is the current long time after the switch is closed?\_\_\_\_\_

What is the time constant of this circuit?\_\_\_\_\_