

Conscious control of a single electron

*Ronald Bryan, Department of Physics, Texas A&M University,
College Station, TX 77843*

June 26, 2004

ABSTRACT

I consider the possibility that the electron, not a human observer, precipitates the collapse of the electron's wavefunction when it is detected. This would seem to endow the electronic wavefunction with an elementary consciousness. If so, then perhaps a human consciousness could interact with the electronic consciousness to flip its spin. I propose an experiment to test this possibility, namely one in which the electron is the single valence electron of a barium ion immersed in a 50-gauss magnetic field. A dye laser shines on the ion and is tuned to bring about laser induced fluorescence (LIF). The LIF is so bright that the ion can be seen with the naked eye. If a person can now lower the electron's energy minutely, then this will flip the electron's spin and the LIF will cease. If the person can succeed in flipping the electron's spin once again by raising its energy, then LIF is restored. By initiating LIF for long and short periods, such a person could send a lengthy International Morse Code message which could be read by anyone observing the ion.

We would see if a person succeeding in this task could send a message from increasingly distant points. If so, then the person's control could not be mediated by any fields currently known to physicists: electromagnetic, weak, strong, and gravitational. We would hypothesize a new kind of field which does not weaken with distance, nor be attenuated by obstructions. Such a field might mediate distant healing and remote viewing. It might be identified with Chinese qi.

We hypothesize that this conjectured field propagates in higher dimensional space-time to avoid obstructions, and converges on the target to avoid weakening. In this space, the field might travel faster than light does in the lower four dimensions of space and time.

RESUME

Je considère la possibilité qu'un électron, et non pas un observateur humain, puisse précipiter l'effondrement de la fonction d'onde de l'électron lorsqu'il est détecté. Ceci semblerait doter la fonction d'onde électronique d'une conscience élémentaire. Si tel était le cas, une conscience humaine pourrait interagir avec la conscience électronique pour renverser son spin (spin-flip). Je propose une expérience pour tester cette possibilité, où l'électron utilisé est l'unique électron de valence d'un ion de baryum immergé dans un champ magnétique de 50 gauss. Un laser à colorant éclaire l'ion, et il est réglé de façon à produire une fluorescence induite par

laser (FIL). La FIL est si éclatante qu'elle pourrait être vue à l'oeil nu. Si une personne peut maintenant renverser le spin de l'électron, la FIL cesse. Si la personne parvient à renverser à nouveau le spin de l'électron, alors la FIL est rétablie. En initiant la FIL pour des périodes longues et courtes, la personne pourrait envoyer un message d'une longueur considérable en code Morse International, qui pourrait être lu par quiconque observe l'ion.

Nous verrons ensuite si la personne qui réussit à accomplir cette tâche peut envoyer un message à partir d'endroits de plus en plus lointains. Si tel était le cas, alors le contrôle émis par cette personne ne serait pas porté par les champs actuellement connus des physiciens, soit les champs électromagnétique et gravitationnel et les interactions faible et forte. Nous faisons l'hypothèse d'un nouveau champ qui ne faiblit pas avec la distance, et qui n'est pas non plus atténué par les obstacles. Un champ de ce genre pourrait transmettre la guérison et la vision à distance. Il pourrait être identifié avec le Qi chinois.

Nous faisons l'hypothèse que ce champ qui reste à découvrir se propage dans une dimension espace-temps plus élevée pour éviter les obstacles, et converge sur la cible pour éviter l'atténuation. Il pourrait voyager plus rapidement que ne le fait la lumière dans les quatre dimensions inférieures de l'espace et du temps.

key words: electron, wavefunction collapse, consciousness, laser-induced fluorescence, Qi, higher dimensional space-time

I. INTRODUCTION

Consider an electron's wavepacket passing through a double slit. It turns into an array of packets, two of which are sketched in Fig. 1.

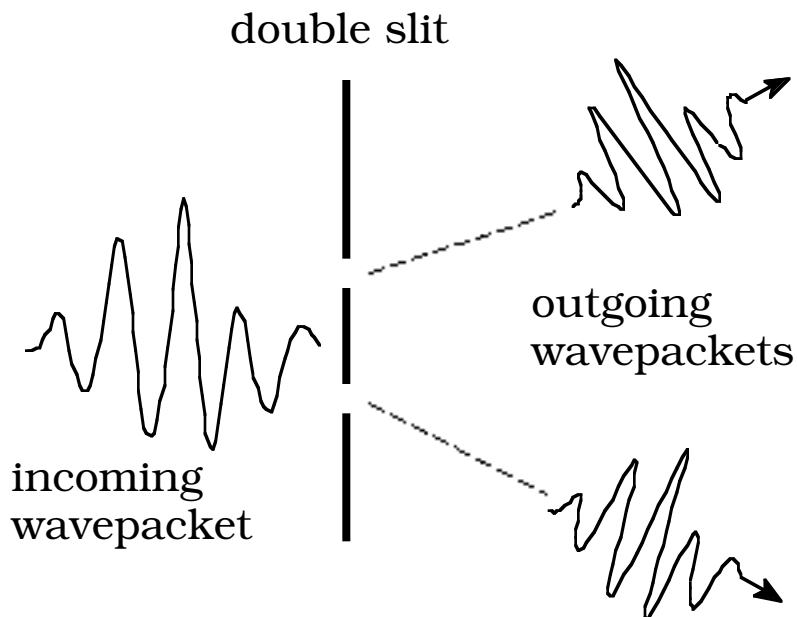

Fig. 1. Wavepacket passing through double slit and undergoing diffraction. Two of the many outgoing wavepackets are sketched.

If an array of detectors is placed to intercept the wavepackets, then only one detector will be activated. According to the Copenhagen School, an observer brings this about (*e. g.*, Ref. 1). Quantum mechanics itself cannot say which detector will be energized. However I will speculate that the electron wavefunction itself “chooses” which detector to activate².

Next consider an electron with its spin in the x -direction approaching, in the y -direction, a Stern-Gerlach device whose highly divergent magnetic field is oriented in the z -direction. If the electron's wavefunction ψ is expanded in terms of spin “up” and “down” states in the z -direction, *i. e.*,

$$\psi = \frac{1}{\sqrt{2}}|\uparrow\rangle + \frac{1}{\sqrt{2}}|\downarrow\rangle,$$

then upon passing through the detector either the electron will be deflected upward with spin up or deflected downward with spin down, as sketched in Fig. 2.

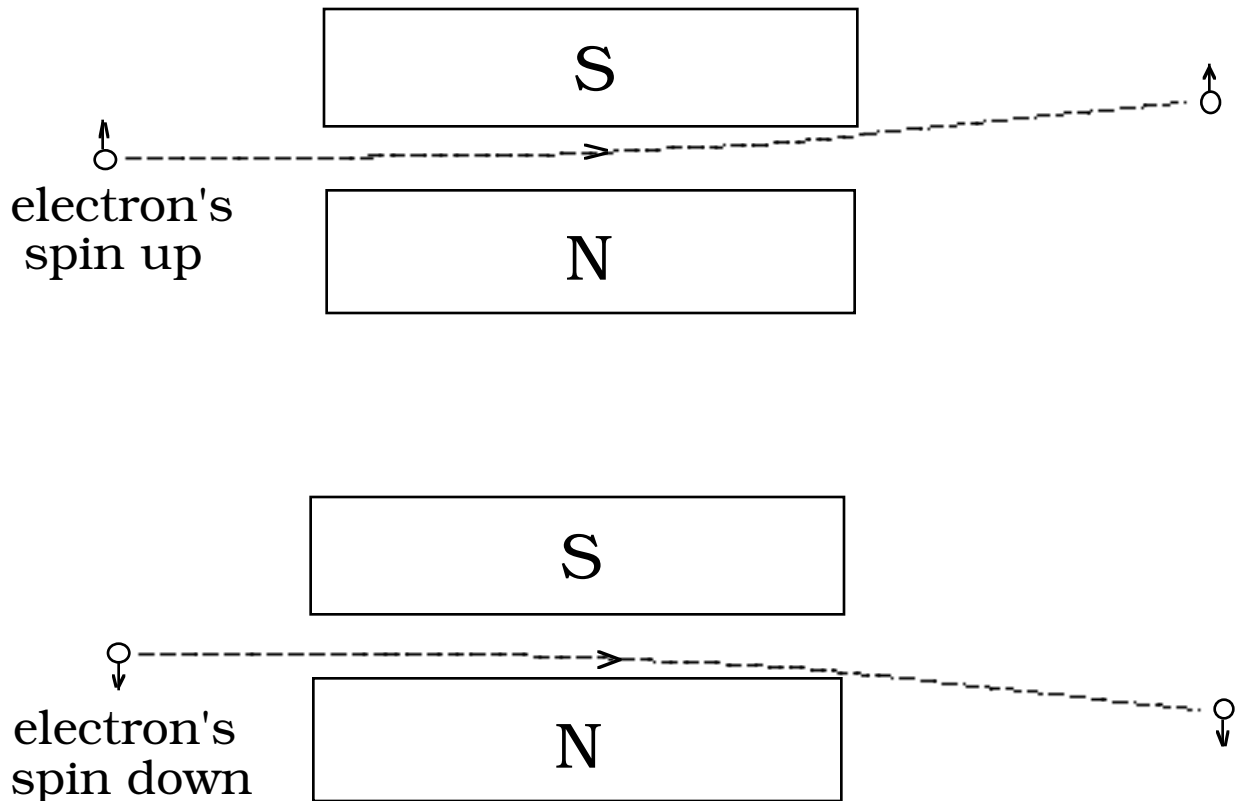

Fig. 2. Highly divergent magnetic field between poles of a Stern-Gerlach device causing electron with spin “up” to be deflected upward, and electron with spin “down” to be deflected downward.

As before, quantum mechanics cannot say which spin-direction the electron will assume; I will speculate that the electron wavefunction chooses.

Finally consider two electrons A and B “entangled” in a state of total spin angular momentum $S=0$ with wavefunction

$$\psi = \frac{1}{\sqrt{2}} |A\uparrow, B\downarrow\rangle - \frac{1}{\sqrt{2}} |A\downarrow, B\uparrow\rangle,$$

where $|A\uparrow, B\downarrow\rangle$ denotes electron A with spin up and electron B with spin down, and $|A\downarrow, B\uparrow\rangle$ denotes the opposite assignments. If electron A's spin is measured in a Stern-Gerlach device and found to be pointing up, then according to most physicists' interpretation of quantum mechanics, this immediately cancels the second term in the wavefunction so that electron B's spin must instantly point down. Similarly, if electron A's spin is measured and found to be pointing down, then this immediately cancels the first term in the wavefunction so that electron B's spin must instantly point up³. It is as if the electrons were aware of each other, consistent with my conjecture that the electron's wavefunction possesses some kind of elementary consciousness.

[Although such entanglement has not been measured for electrons, it has been measured for pairs of *photons* in laboratories over short distances and also over several miles, as reported by Weihs *et al.*⁶ and Gisin⁷ and references cited therein. Indications are that indeed, upon measurement of A's spin, B's spin is instantly determined, or at least far sooner than the speed of light would permit.]

In the three electron examples cited, quantum mechanics cannot predict in which wavepacket the electron will materialize, in which direction the electron's spin will point, or how the information gets from electron A to electron B. If an electron's consciousness indeed plays a role in quantum mechanics, then consciousness must be an aspect of the electron's wavefunction. I will therefore refer to it as the *conscious electron wavefunction*. (See also Ref. 8.)

If electrons have some kind of a primitive conscious wavefunction, then presumably the other elementary particles do too. This will include the other first-generation particles: the up and down quarks and the electron-neutrino. Since protons and neutrons are composed primarily of the quark triplets (up, up, down) and (down, down, up), respectively, they should also have primitive conscious wavefunctions. Atoms and molecules, being composed of quarks and electrons, will likewise exhibit some kind of elementary consciousness, and so on up the chain until we reach human beings.

Human beings, being composed of atoms and molecules, of course have a (highly complex) wavefunction. If the elementary particles' wavefunctions embody consciousness, then the human wavefunction should embody consciousness too. Is this where human consciousness resides? Can it be that the human wavefunction and human consciousness are but two

aspects of the same thing? I will speculate in the affirmative and call it the *conscious human wavefunction*.

This suggests an experiment. If a human's wavefunction is conscious, and an electron's wavefunction is conscious, then perhaps the human's consciousness can have an effect on an electron's consciousness. In particular, perhaps a human consciousness can reverse the spin-direction of an electron. The person's consciousness might affect the electron by means of a field. A possible field is sketched in Fig. 3. For definiteness, I will call it the M-field.

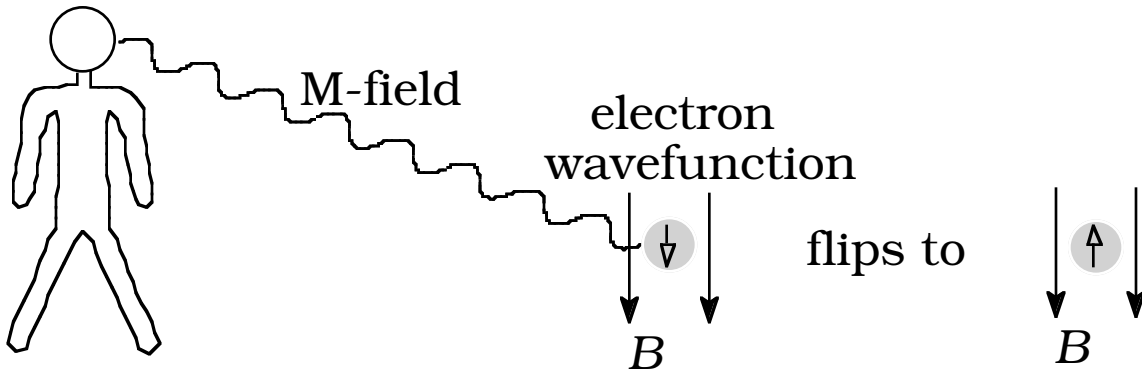

Fig. 3. Human consciousness reversing the spin of an electron in a magnetic field B by means of a conjectured M-field.

II. AN EXPERIMENT

How can we tell if a human consciousness has flipped the spin of an electron? Here is one way. Put the electron in a weak magnetic field, say 50-gauss. According to the laws of quantum mechanics, the electron's spin, and hence its magnetic moment, can only point along the magnetic field lines, or opposite them (*e. g.*, Ref. 9). No other state is allowed. The electron's magnetic moment is like a little bar magnet or magnetic compass needle. Thus the electron is in a state of higher energy when its magnetic moment is opposed to the magnetic field than when it points along the field. For example, in the 50-gauss magnetic field, an electron pointing against the field has about $0.6 \cdot 10^{-6}$ eV more energy than one pointing along the field. So if by conscious intent a person could "push" an electron which is in the higher energy state down to the lower energy state, then this would reverse the spin of the electron.

How can we tell if the electron's energy has changed? One way is to take a twice-ionized barium atom (whose remaining electrons form tight closed shells) and add our electron to it. This electron will now be a valence electron with a spherically symmetric wavefunction which surrounds the much smaller inner electronic shells of the barium ion. Our electron wavefunction will still retain its spin.

Now shine a tunable dye laser on the barium ion. When the exact resonance frequency is reached, the ion will light up. You can see its blue-violet light with your naked eye! This is called laser-induced fluorescence (LIF). If a person can now depress the valence electron in energy, thus reversing its spin, then this energy change, although slight, will be enough to kill the resonance. The ion will become dark.

It might take some practice before the person is able to depress the valence electron's energy so as to flip its spin, perhaps considerable practice even for a gifted subject. However once he or she can do it, then others should feel that they can too. It might be like learning to ride a bicycle. Once you see someone ride a bicycle, you know that (most likely) you can too, although the skill might not come at once.

If a person who can lower the valence electron's energy can subsequently raise it the same amount, then the ion will shine again. To make sure that these changes are not due to static, the person might cause the ion to be light for long and short times. If he or she causes the ion to be: light, dark, light, dark, light, dark, llllight, dark, llllight, dark, llllight, dark, light, dark, light, dark, light, dark, then this person has just sent the signal $\cdot \cdot \cdot - - - \cdot \cdot \cdot$, or SOS in International Morse Code. Anyone watching the ion could read the message. The operator could send the Preamble to the U. S. Constitution.

Here in more detail is how the experiment works. We bind our electron in a spherically symmetric $6s$ state enclosing the xenon-like core of a $^{138}\text{Ba}^{++}$ ion and then confine the resulting $^{138}\text{Ba}^+$ ion in a Paul trap in a volume of $\sim 1\text{cm}^3$ at an extremely low pressure of about 10^{-10} to 10^{-11} torr. A laser-photon of wavelength $\lambda = 455\text{nm}$ and energy $h\nu = 2.72\text{eV}$ excites the electron from the $6s_{1/2}, m_j = 1/2$ state to the $6p_{3/2}, m_j = 3/2$ state. The excited electron returns to its original state emitting another photon of the same wavelength λ (see Fig. 4), but in an arbitrary direction. This sequence is repeated up to 10^8 times/sec. so the ion emits up to 10^8 photons/sec. The pupil of a human eye can accept about 10^4 of these photons/sec, so the ion should be visible.

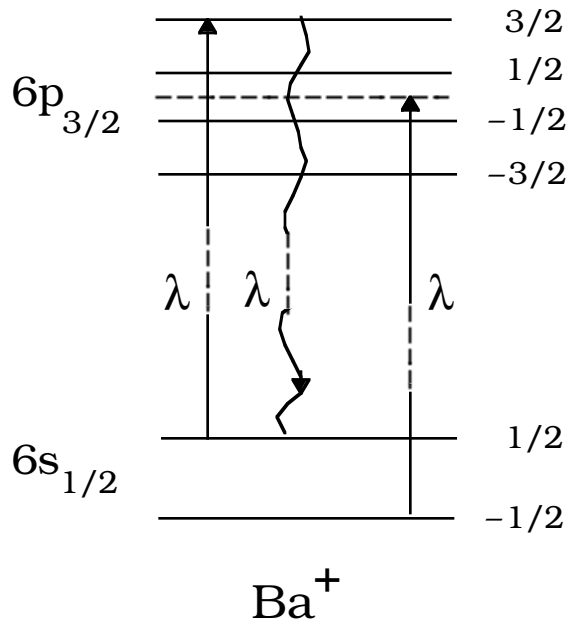

Fig. 4. Relevant energy spectrum of the valence electron of Ba^+ immersed in a magnetic field. The jump in energy from the $6s_{1/2}$ to the $6p_{3/2}$ levels is several orders of magnitude greater than it appears in the sketch. Laser-induced fluorescence (LIF) can occur when an electron in the upper $6s_{1/2}$ level can absorb a photon of wavelength λ , jump to the highest $6p_{3/2}$ level, then re-emit the photon and return to the upper $6s_{1/2}$ level. If the electron is initially in the *lower* $6s_{1/2}$ level, then absorbing the same photon of wavelength λ can excite it only as high as the dotted line in the middle of the $6p_{3/2}$ multiplet, where no level exists. Then LIF cannot occur. Data taken from Moore¹⁰.

Let us suppose that we have bathed the barium ion in a magnetic field of strength $B = 50$ gauss. Then the energy levels of the valence electron are split *very* slightly. The $6s_{1/2}$ ground states are split by $0.6 \cdot 10^{-6}$ eV and the $6p_{3/2}$ states by $0.4 \cdot 10^{-6}$ eV. If the electron is in, say, the upper $6s_{1/2}$ level and a person now depresses the electron to the lower $6s_{1/2}$ level, then LIF will cease because the $\lambda = 455$ nm laser photons will be trying to excite the electron to the dashed line in the $6p_{3/2}$ spectrum where no state exists. Thus we will know that the spin of the valence electron has been flipped.

III. A NEW KIND OF FIELD?

If a person seated next to the apparatus can manipulate the valence electron to send an International Morse Code message, then we will have him or her try to send a message from across town. If he or she is still

successful, then we will have the person try to send a message to the valence electron from across the state, from across the country, and perhaps from across an ocean. If the person can still send International Morse Code messages, then we will know that he or she is not influencing the electron using any of the forces currently known to physicists: electromagnetic, weak, strong, and gravitational.

What mechanism might the person be using? Perhaps the same mechanism that enables distant healing¹¹, remote viewing¹², Chinese qi-gong¹³, and other phenomena. These phenomena have certain features in common:

1. The command goes to the target without weakening, even though the target may be far away. (Compare this with electromagnetic waves which fan out as they propagate and thus weaken inversely proportional to the distance traveled, as described in *e. g.*, Ref. 14.)

- a. Distant healing can be effective even when the healers are far from the person being helped, and when neither the person nor his doctor knows that he is being helped, as Larry Dossey and Jonas & Crawford report¹¹. The healers can be effective even half-way around the world from the patient.

- b. Remote viewing, which I think involves the viewer's sending a leading signal to the target and information's returning along this path to the viewer (analogous to lightning in which a leader is followed by a full return stroke), can be just as revealing when the target is far away. For example, the world-class remote viewer Joseph McMoneagle, just sitting in his living room in Virginia, reports how he discovered the whereabouts of a person in Japan¹². All he was given to work with was the name of the person put in an unmarked sealed envelope, which envelope he *never opened*. He continues to find other people in this fashion. These remarkable finds are being commissioned and reported by a television station in Japan (channel 4 in Tokyo).

- c. In a careful study, Yan *et al.* report that Dr. Xin Yan used qi-gong to reduce by about 1% the decay rate of a ²⁴¹Am radioactive source in Beijing, China when he was in Kunming, 2200 km away¹³. The reaction is $^{241}\text{Am} \rightarrow ^{237}\text{Np} + \alpha$, with a half-life of 458 years. A reduction of 1% is a small amount, but it was nine times the experimental error, so the chance that this reduced decay rate was just due to statistics is less than one part in 10 billion. Furthermore, Yan *et al.* report that Yan altered the decay rate of this source much more when he was even farther away, in California¹³.

2. The effect is not attenuated by obstructions. Clearly, when healers can help a patient half-way around the world, when a remote viewer can look in on Japan as easily as nearby, and when a qi-gong master can change the decay rates of a nuclear sample an ocean away, their signals are not being obstructed by earth, water, concrete, *etc.*

I propose that if a person is able to control a valence electron in the manner described earlier, then a new kind of field mediates this control.

This field may also mediate distant healing, remote viewing, Chinese qi-gong, *etc.* It will be such that it is neither weakened by distance nor by obstructions. I will call it the M-field because it appears to be similar to the M-field reported by Monroe¹⁵ and the morphic field conjectured by Sheldrake¹⁶.

The M-field might be something like the gluon fields of Quantum Chromodynamics, *e. g.*, Ref. 17, which also do not weaken with distance but go directly to their target. However the gluon fields would have to be generalized to propagate over long distances.

These fields suggest another possibility for the M-field. Gluon fields come in eight “colors”. Could the M-field also come in eight “colors”, with one color carrying healing intent (*cf.* Dossey, and Jonas & Crawford), another color carrying information (McMoneagle's remote viewing), another color carrying light and interacting with electrical charge (our proposed experiment), another color interacting like gluons with quarks so as to affect nuclear matter (Yan's altering nuclear decay rates), *etc.*?

With regard to the M-field's not being affected by obstructions, a mechanism that appeals to me as a researcher of higher dimensional fields, *e. g.*, Ref. 18, is that the signal propagates to the target on a path outside the lower four dimensions of space and time. This is illustrated in Fig. 5. The signal “rises above” obstructions in the lower four dimensions¹⁹.

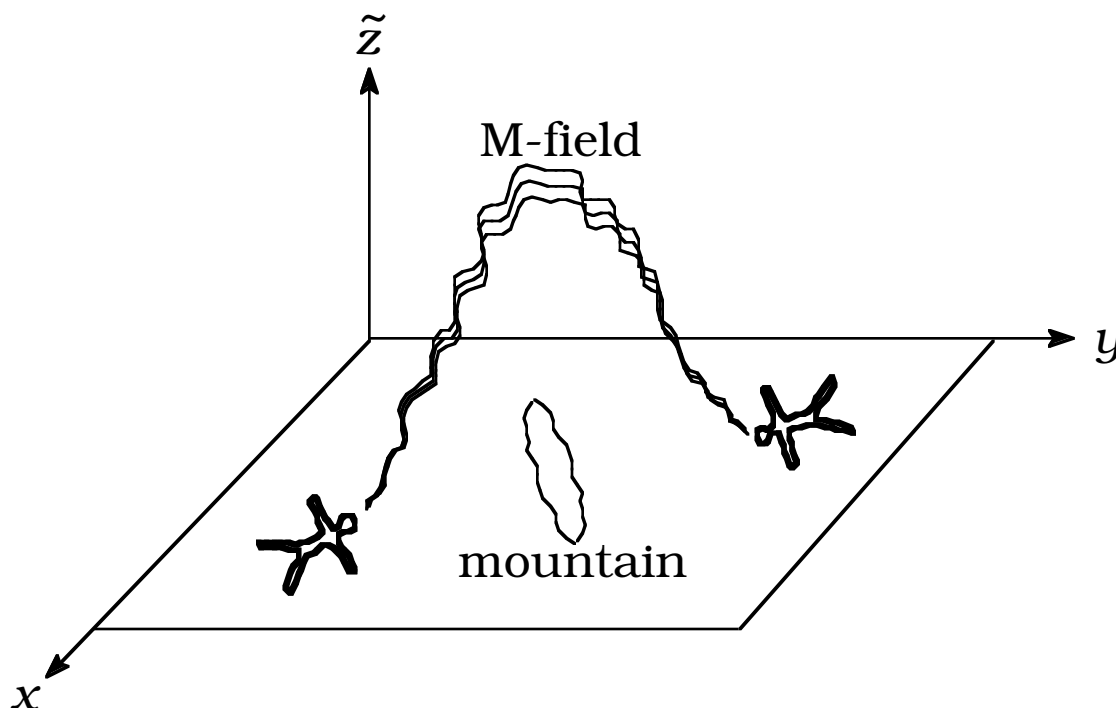

Fig. 5. To visualize an extra dimension, imagine that we live in just a two-dimensional x, y plane, as in Abbott's Flatland²⁰. The extra dimension rises vertically from our plane and is denoted z -twiddle (\tilde{z}). We can't see in that

direction, nor can our telescopes or any other scientific instruments created by humans. However I hypothesize that the M-field can propagate in this extra dimension \tilde{z} . In the figure, the field is emitted by one person, rises above a two-dimensional mountain, and is received at full strength by another person.

Such a higher-dimensional field is similar to a five-dimensional life-energy field described by Swejen Salter²¹.

If the signal really is propagating outside the lower dimensions of space and time, then it should not be constrained by our time. Thus we might ask the person to try to send Morse Code commands which will not affect the valence electron until, say, two hours later.

Such a delayed reaction might be possible: McMoneagle documents a somewhat similar experience. In remote-viewing a location in California, he saw a “multi-story high-tech building with off-set balconies and hanging gardens”. In fact, located at this site was “a lumber yard attached to a small hardware store”, so his description was deemed a miss. However, driving by the location nearly a year later, he found that the lumber yard and store “had been bulldozed away and replaced with a new building of concrete and glass. The balconies of the building were offset and had lots of green plants hanging from their ledges”. (Ref. 22) I interpret this to mean that McMoneagle's command for information went to the site as it existed about a year in the future. Time-translated experiences like this are not uncommon in remote-viewing.

A long-range test of the M-field might be to see if a person could send a message to a valence electron on Mars in less than the few minutes required for an electromagnetic field to reach Mars. Perhaps an astronaut on Mars could receive a message from Mission Control in a few seconds or milliseconds, and then send a response back to Mission Control. If the time required for the round trip were, say, a few seconds, then we would know that the message had traveled at speeds far exceeding Einstein's Speed Limit, 186,000 miles/sec. This would prove that the signal had indeed traveled outside of our four lower dimensions, perhaps as sketched in Fig. 5

Of course, such an experiment could only happen far in the future, if at all. But if we could generate the M-field electronically, perhaps by using a microwave generator to cause the barium valence electron to make rapid transitions between its two $6s_{1/2}$ ground states, then it might be possible to measure the speed of the M-field right here on Earth. Furthermore the speed could most likely be measured with great precision. This would determine once and for all if the M-field propagates at a speed exceeding the speed of light in the lower four dimensions.

Acknowledgments

I would like to thank David Church for explaining how laser-induced fluorescence can reveal electron spin-flip. I would especially like to thank Hans Schuessler for showing me a related experimental set-up. Vladimir Ryjkov helped explain some experiment details. A week-end gathering of some two dozen of us grantees of the Lifebridge Foundation of New York City helped me to develop the idea of a conscious electron wavefunction, and I thank the Foundation for its support. I would also like to thank Brian Stagner for discussing the psychology involved in learning a new skill, and Mary Dillman for researching the Jane Roberts reference. Also I am indebted to Beverly Rubik for directing me to published articles on distant healing.

References

- ¹ E. P. Wigner, Remarks on the mind-body question, in *Symmetries and Reflections* (Ox Bow Press, Woodbridge, Connecticut, 1979), p. 171.
- ² Note that I write “wavefunction”. If the reader thinks that an electron is a tiny particle like a tiny BB, then he or she is not likely to think that it can possess a consciousness, even a primitive one. But if the reader thinks, as most theoretical physicists do, that an electron is basically a *wavefunction* and as much an idea as physical reality, and furthermore that it can sometimes be “aware” of another electron over vast distances (as in the correlated electrons experiment described below), then attributing a minimal consciousness to it might not seem quite so strange.
- ³ This is David Bohm's version⁴ of the Einstein-Podolsky-Rosen experiment⁵.
- ⁴ D. Bohm, *Quantum Theory* (Prentice-Hall, New York, NY, 1951).
- ⁵ A. Einstein, B. Podolsky, and N. Rosen, “Can quantum-mechanical description of physical reality be considered complete?” *Physical Review* **47**, 777 (1935).
- ⁶ G. Weihs, T. Jennewein, C. Simon, H. Weinfurter, and A. Zeilinger, “Violation of Bell's inequality under strict Einstein locality conditions,” *Physical Review Letters* **81**, 5039 (1998).
- ⁷ N. Gisin, “Sundays in a quantum engineer's life,” Talk presented at the *Conference in Commemoration of John S. Bell* (Vienna, November 10–14, 2000). <http://xxx.lanl.gov/abs/quant-ph/0104140>
- ⁸ “Molecules and atoms and even smaller particles have a condensed consciousness. They form into cells and form an individual cellular consciousness.” J. Roberts, *The Seth Material* (Prentice-Hall, Englewood Cliffs, NJ, 1970), p. 113.

- ⁹ J. J. Sakurai, *Modern quantum mechanics*. (Addison-Wesley, New York, 1985).
- ¹⁰ C. E. Moore, *Atomic Energy Levels, Volume III* (NBS Circular 467). (National Bureau of Standards, Gaithersburg, MD, 1958).
- ¹¹ L. Dossey, *Reinventing Medicine* (HarperCollins, New York, 1999); Wayne B. Jonas and Cindy C. Crawford, "Science and spiritual healing: a critical review of spiritual healing, 'Energy' medicine, and intentionality", *Alternative Therapies Supplement: Definitions and Standards in Healing Research* **9**, A56 (2003). Jonas and Crawford review a series of meta-analyses, including a study of 13 randomized trials looking for the effect of distant healing and prayer on 2,328 patients. Six (46%) trials reported statistically significant effects.
- ¹² J. McMoneagle, *The Stargate Chronicles* (Hampton Roads, Charlottesville, VA, 2002), p. 261.
- ¹³ X. Yan, F. Lu, M. Jiang, X. Wu, W. Cao, Z. Xia, H. Shen, J. Wang, M. Dao, H. Lin, and R. Zhu, "Certain physical manifestation and effects of external qi of Yan Xin Life Science Technology", *Journal of Scientific Exploration* **16**, 381 (2002).
- ¹⁴ J. D. Jackson, *Classical electrodynamics* (John Wiley, New York, 1962).
- ¹⁵ R. Monroe, R., *Ultimate Journey* (DoubleDay, New York, 1994).
- ¹⁶ R. Sheldrake, *A New Science of Life: the Hypothesis of Morphic Resonance* (Inner Traditions International, Rochester, VT, 1995).
- ¹⁷ T.-P. Cheng and L.-F. Li, *Gauge Theory of Elementary Particle Physics* (Oxford University Press, New York, 1984).
- ¹⁸ R. Bryan, *Nuclear Physics* **B523**, 232 (1998).
- ¹⁹ R. Bryan, *Journal of Scientific Exploration* **14**, 257 (2000).
- ²⁰ E. A. Abbott, *Flatland, a Romance of Many Dimensions*, 6th ed. (Dover, New York, 1952).
- ²¹ S. Salter, In: *C. E. T. L. Luxembourg Newsletter*, ed. Maggy Harsch-Fischbach (January Issue, 1990).
- ²² J. McMoneagle, *Mind Trek* (Hampton Roads, Charlottesville, VA, 1997), p. 135