

Physics 202 MWF 10:20 Spring 2008 (Ford)

Name (printed) _____

Name (signature as on ID) _____

Lab Section _____

Final Exam

Show all your work. Partial credit will be given if earned. Write your answers in the blanks provided.

(8 pts) 1. The electric potential at point A is $+8000$ V. A negative point charge $q = -5.0 \times 10^{-4}$ C is released from rest at point A . When the point charge reaches point B , which is 2.0 m to the right of point A , its kinetic energy is 6.0 J. What is the electric potential at point B ?

Ans. _____

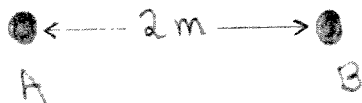

(10 pts) 2. A negative point charge $q_1 = -4.0 \times 10^{-9} \text{ C}$ is at the origin and a positive point charge $q_2 = +6.0 \times 10^{-9} \text{ C}$ is on the $+x$ -axis at $x = 0.40 \text{ m}$. Point A is at $x = -0.20 \text{ m}$ and point B is at $x = -0.50 \text{ m}$.

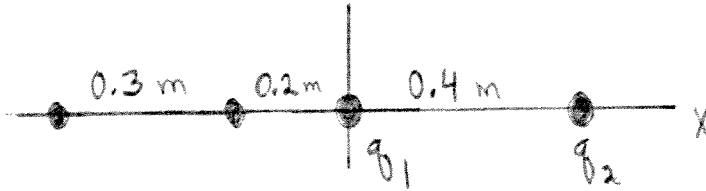

a) What are the magnitude and direction of the net electric field at point A , due to the two point charges?

Ans. $E =$ _____

direction _____

b) What is the potential difference $V_A - V_B$? Which point is at higher potential, A or B ?

Ans. $V_A - V_B$ _____

point that is at higher potential _____

(10 pts) 3. Three capacitors are connected to a battery as shown in the sketch. $C_1 = 3.0 \times 10^{-6}$ F, $C_2 = 6.0 \times 10^{-6}$ F and $C_3 = 5.0 \times 10^{-6}$ F. When the capacitors have reached their final charges, the charge on C_1 is $q_1 = 3.0 \times 10^{-4}$ C.

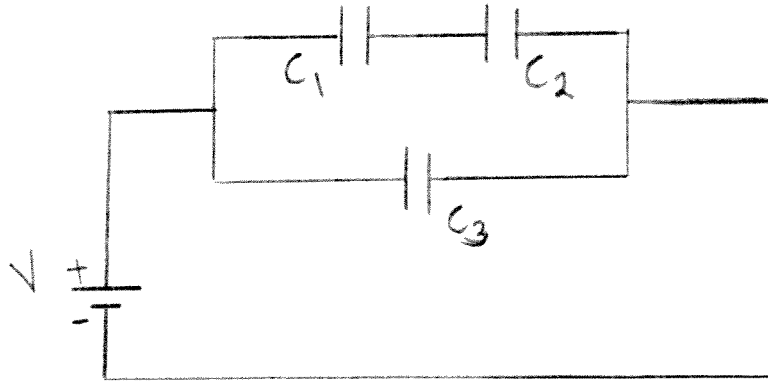

a) What is the voltage V_2 across C_2 ?

Ans. _____

b) What is the charge q_3 on C_3 ?

Ans. _____

(10 pts) 4. Consider the circuit shown in the sketch. Note that two currents are given. What is the emf of each battery?

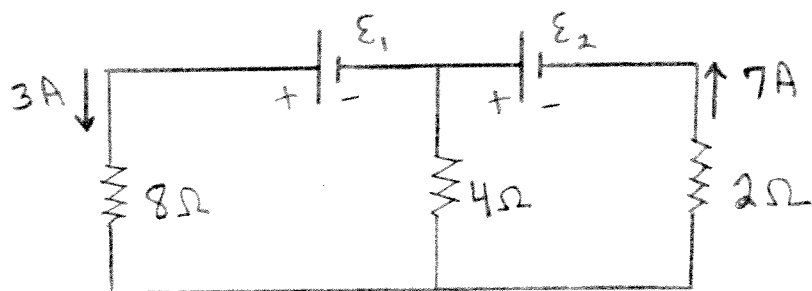

Ans. $\epsilon_1 =$ _____
 $\epsilon_2 =$ _____

(8 pts) 5. A long straight wire carries current $I = 6 \text{ A}$ in the direction shown in the sketch. A small particle with negative charge $q = -5 \times 10^{-6} \text{ C}$ is moving near the wire. When the particle is 0.20 m from the wire and moving with speed $v = 400 \text{ m/s}$ in the direction shown in the sketch. what are the magnitude and direction of the force that the wire exerts on the particle?

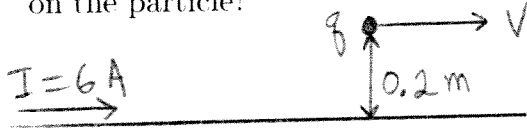

Ans. magnitude _____
 direction _____

(4 pts) 6. A square conducting loop is at rest to the left of a long straight wire. The wire carries current I in the direction shown in the sketch. If the current in the wire is decreasing, is the current induced in the loop clockwise, counterclockwise or zero?

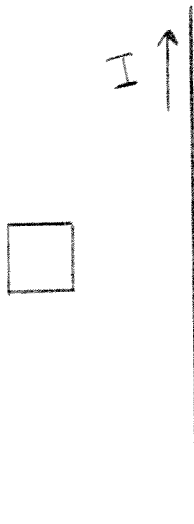

Ans. _____

(10 pts) 7. Consider the ac circuit shown in the sketch. $R = 150 \Omega$ and $C = 5.0 \times 10^{-6} \text{ F}$. The source voltage amplitude is 800 V and the current amplitude is 2.0 A.

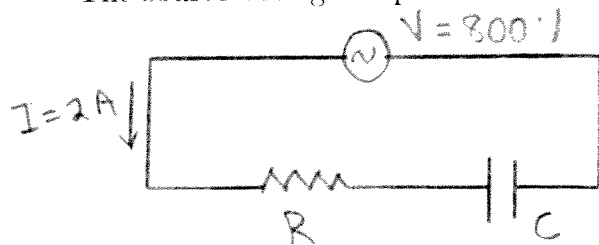

a) What is the amplitude of the voltage across the capacitor?

Ans. _____

b) What is the angular frequency ω of the source?

Ans. _____

c) What is the rate at which the source is supplying electrical energy to the circuit?

Ans. _____

d) Does the source voltage lag or lead the current in the circuit?

Ans. _____

(8 pts) 8. When a 4.0 mm tall object is 40.0 cm to the left of a lens, an upright image is formed that is 2.0 mm tall.

a) Is the image to the left of the lens or to the right of the lens?

Ans. _____

b) How far is the image from the lens?

Ans. _____

c) Is the lens converging ($f > 0$) or diverging ($f < 0$)?

Ans. _____

(8 pts) 9. The maximum wavelength of light that will produce photoelectrons from a certain surface is 600 nm. What is the maximum kinetic energy of the photoelectrons produced from the same surface when light of wavelength 400 nm is used?

Ans. _____

(8 pts) 10. A thin film with thickness t coats a flat piece of glass. There is air above the film. The film has $n = 1.2$ and the glass has $n = 1.5$. Light of wavelength 400 nm in the air strikes the film at normal incidence. What is the smallest thickness of the film for which there will be destructive interference between the light reflected at the upper and lower surfaces of the film?

Ans. _____

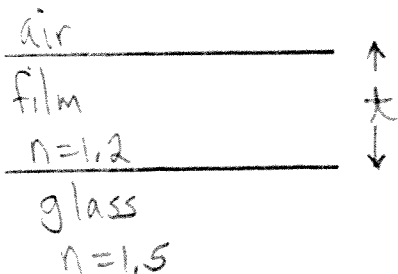

(4 pts) 11. The nucleus $^{19}_8\text{O}$ undergoes β^- decay. How many neutrons are there in the nucleus that is produced by this decay?

Ans. _____

(6 pts) 12. The mass of a neutral ${}^2_1\text{H}$ atom is 2.014101 u. Calculate the binding energy of the ${}^2_1\text{H}$ nucleus. in MeV.

Ans. _____

(6 pts) 13. The nucleus ${}^{230}_{92}\text{U}$ undergoes α -decay with a half-life of 20.8 days. How many alpha particles are emitted per second by a sample that contains 8.0 g of ${}^{230}_{92}\text{U}$?

Ans. _____