

Name (printed) Version 1

Name (signature as on ID) Key

Lab Section \_\_\_\_\_

Exam II Chaps. 19-21 in Young&Geller

Multiple choice questions. Circle the correct answer. No work needs to be shown and no partial credit will be given.

(6 pts) 1. Consider the circuit shown in the sketch. Initially switch  $S$  is open. When the switch is closed, the current through  $R_3$

- b
- (a) increases
  - (b) decreases**
  - (c) stays the same
- $R_{eq}$  decreases  
 $I$  increases  
 $V_1$  increases  
 $\Sigma = V_1 + V_3$  so  $V_3$  decreases  
 $I_3$  decreases

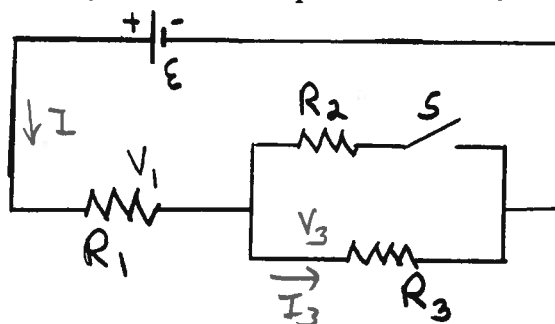

(6 pts) 2. In the circuit shown in the sketch, switch  $S$  is closed and left closed a long time. Then it is opened. Just after the switch is opened, the current through the  $2\ \Omega$  resistor is

- c
- (a) zero
  - (b) 6 A
  - (c) 10 A**
  - (d) 15 A
  - (e) 60 A
  - (f) none of the above answers
- after closed a long time  
 $I = \frac{30V}{3\Omega} = 10A$   
 same  $I$  through inductor  
 right after switch opened, so 10A

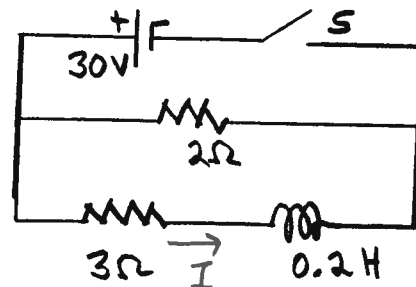

(6 pts) 3. A particle with negative charge is traveling to the left with speed  $v$ . The particle passes through a region between two horizontal plates that carry equal and opposite charges, as shown in the sketch. Gravity can be neglected. The direction of the minimum magnetic field in the region between the plates that allows the particle to pass through the region undeflected is

- a
- (a) into the page**
  - (b) out of the page
  - (c) to the left
  - (d) to the right
  - (e) toward the top of the page
  - (f) toward the bottom of the page

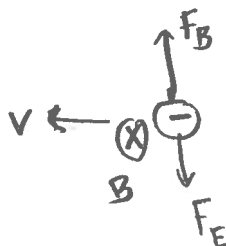
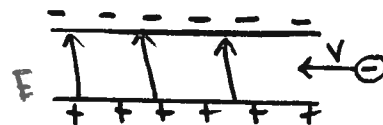

(6 pts) 4. A straight segment of wire is in a region of uniform magnetic field. If the current in the wire is toward the right and the direction of the magnetic field is into the page, as shown in the sketch, the direction of the force on the wire is

- (a) into the page
- (b) out of the page
- (c) to the left
- (d) to the right
- (e) toward the top of the page
- (f) toward the bottom of the page

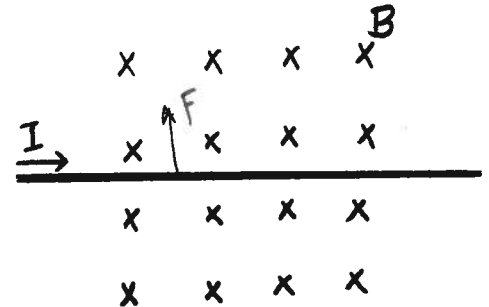

(6 pts) 5. Point  $P$  is at the center of a circular loop of wire. Current  $I$  travels around the loop in a clockwise direction, as shown in the sketch. The magnetic field at point  $P$  is

- (a) zero
- (b) into the page
- (c) out of the page
- (d) to the left
- (e) to the right
- (f) toward the top of the page
- (g) toward the bottom of the page

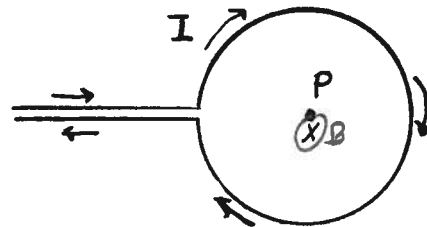

(6 pts) 6. A conducting bar lies on frictionless rails. A resistor  $R$  is connected across the left-hand ends of the rails and all other resistance in the circuit is negligible. The whole apparatus is immersed in a uniform magnetic field that is directed out of the page. The bar is moving to the left with speed  $v$ . Points  $a$  and  $b$  are at each end of the resistor, as shown in the sketch.

- (a) points  $a$  and  $b$  are at the same potential
- (b) point  $a$  is at higher potential than point  $b$
- (c) point  $a$  is at lower potential than point  $b$

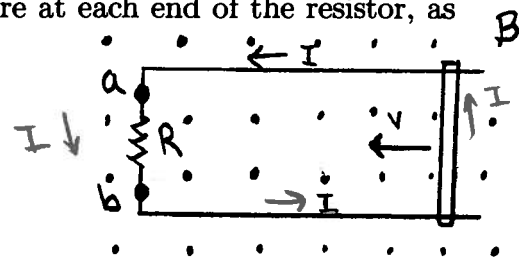

$B \odot, \vec{v} \leftarrow, B_{ind} \odot$

high potential end of  $R$  is where current enters

(6 pts) 7. A  $9.0 \times 10^{-4}$  F capacitor is charged to  $2.4 \times 10^{-3}$  C and then connected across the ends of a 0.040 H inductor. The resistance of the circuit can be neglected. During the subsequent current oscillations, what is the maximum current in the inductor?

- (a) zero
- (b) 0.1 A
- (c) 0.2 A
- d (d) 0.4 A
- (e) 0.8 A
- (f) 1.2 A
- (g) none of the above answers

$$\frac{1}{2} \frac{Q_{\max}^2}{C} = \frac{1}{2} L I_{\max}^2$$

$$I_{\max} = \frac{Q_{\max}}{\sqrt{LC}}$$

$$I_{\max} = \frac{2.4 \times 10^{-3} \text{ C}}{\sqrt{(0.040 \text{ H})(9 \times 10^{-4} \text{ F})}} = 0.4 \text{ A}$$

(6 pts) 8. A conducting loop is to the left of a long straight wire. The loop is stationary. The current in the wire is increasing at a constant rate. The loop has

- (a) zero induced current
- b (b) induced current that is clockwise
- (c) induced current that is counterclockwise

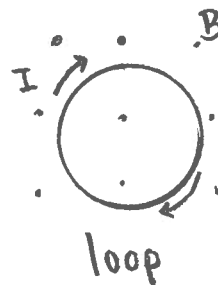

$B \odot, \vec{E}_B$  increasing  
 $B_{\text{ind}} \otimes, I_{\text{cw}}$

$\uparrow I$   
 wire

Show all your work for partial credit. Write your answers in the blanks provided.

(16 pts) 9. The sketch shows a small charged sphere moving toward the left with a speed of  $5.0 \times 10^3$  m/s. The sphere is 0.20 m from a long straight wire that carries a current of 4.0 A that is directed to the right. The sphere has negative charge  $q = -6.0 \times 10^{-9}$  C.

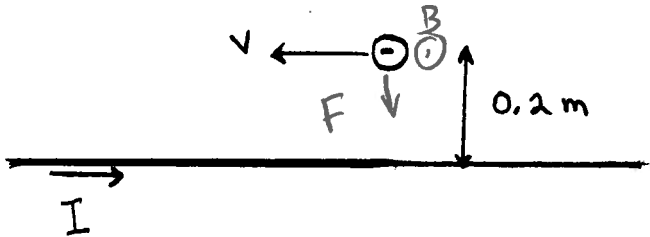

a) At the location of the sphere, what are the magnitude and direction of the magnetic field due to the current in the wire? Show the direction of the magnetic field on the sketch.

$$B = \frac{\mu_0 I}{2\pi r} = \frac{(4\pi \times 10^{-7})(4)}{2\pi(0.2)} = 4.0 \times 10^{-6} \text{ T}$$

Ans.  $B = \underline{4 \times 10^{-6} \text{ T}}$   
 direction  $\odot$  (out of page)

$B \odot$

b) What are the magnitude and direction of the force that the wire exerts on the charged sphere? Show the direction of the force on the sketch.

Ans.  $F = \underline{1.2 \times 10^{-10} \text{ N}}$

direction toward bottom of page

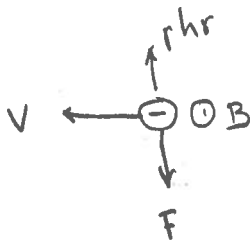

$$F = |q|vB \sin\phi = (6 \times 10^{-9})(5 \times 10^3)(4 \times 10^{-6}) \sin 90^\circ$$

$$F = 1.2 \times 10^{-10} \text{ N}$$

(18 pts) 10. Consider the circuit shown in the sketch.  $R_1 = 3.0 \Omega$ ,  $R_2 = 6.0 \Omega$ ,  $R_3 = 6.0 \Omega$ , and  $R_4 = 12.0 \Omega$ .

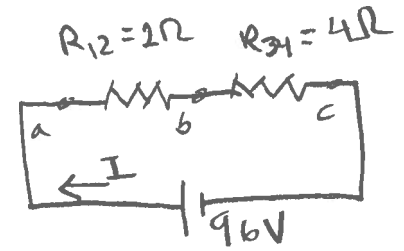
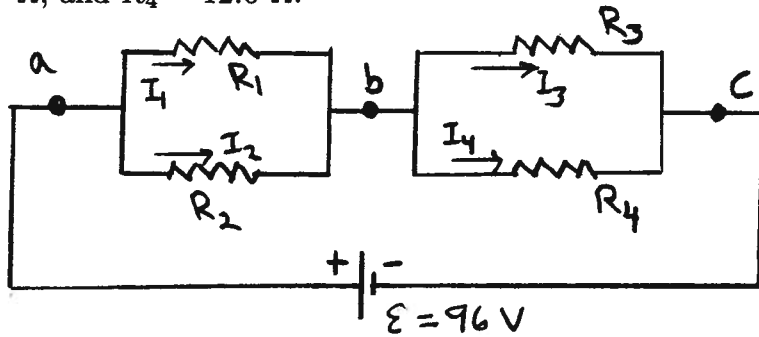

a) What is the potential difference  $V_{ab}$  between points  $a$  and  $b$  and what is the potential difference  $V_{bc}$  between points  $b$  and  $c$ ?

$$I = \frac{96V}{6\Omega} = 16A$$

$$V_{ab} = IR_{12} = 32V$$

$$V_{bc} = IR_{34} = 64V$$

Ans.  $V_{ab} = \underline{32V}$   
 $V_{bc} = \underline{64V}$

Note that  $V_{ab} + V_{bc} = 96V$

b) What is the current through each resistor?

$$I_1 = \frac{V_{ab}}{R_1} = \frac{32V}{3\Omega} = 10.7A$$

$$I_2 = \frac{V_{ab}}{R_2} = \frac{32V}{6\Omega} = 5.3A$$

$$I_3 = \frac{V_{bc}}{R_3} = \frac{64V}{6\Omega} = 10.7A$$

$$I_4 = \frac{V_{bc}}{R_4} = \frac{64V}{12\Omega} = 5.3A$$

Ans.  $I_1 = \underline{10.7A}$   
 $I_2 = \underline{5.3A}$   
 $I_3 = \underline{10.7A}$   
 $I_4 = \underline{5.3A}$

Note that  $I_1 + I_2 = I_3 + I_4 = 16A$

c) What is the current through the emf source (the battery)?

Ans.  $\underline{16A}$

(18 pts) 11. Consider the circuit shown in the sketch. The current in the  $8.0 \Omega$  resistor is  $I_1 = 3.0 \text{ A}$ .

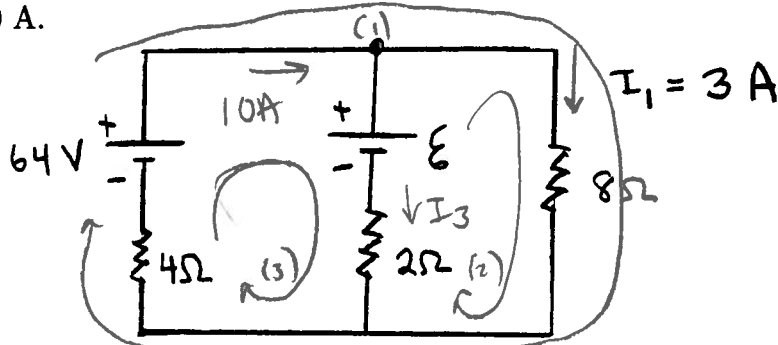

a) What is the current through the  $4.0 \Omega$  resistor?

$$\begin{aligned} \text{loop (1)} \\ +64\text{V} - (3\text{A})(8\Omega) - I_2(4\Omega) &= 0 \\ I_2 &= \frac{64\text{V} - 24\text{V}}{4\Omega} = 10\text{A} \end{aligned}$$

Ans. 10A

b) What is the current through the  $2.0 \Omega$  resistor?

$$\begin{aligned} 10\text{A} &= I_3 + I_1 \\ I_3 &= 7\text{A} \end{aligned}$$

Ans. 7A

c) What is the emf  $\epsilon$ ?

$$\begin{aligned} \text{loop (2)} \\ \epsilon - (3\text{A})(8\Omega) + (7\text{A})(2\Omega) &= 0 \\ \epsilon &= 24\text{V} - 14\text{V} = 10\text{V} \end{aligned}$$

Ans. 10V

loop (3) to check:

$$\begin{aligned} +64\text{V} - \epsilon - I_3(2\Omega) - I_2(4\Omega) &\stackrel{?}{=} 0 \\ 64\text{V} - 10\text{V} - 14\text{V} - 40\text{V} &= 0 \checkmark \end{aligned}$$