

Name (printed) _____

Name (signature as on ID) _____

Lab Section _____

Final Exam

Show all your work. Partial credit will be given if earned. Write your answers in the blanks provided.

(10 pts) 1. Negative point charge $q_1 = -8.0 \times 10^{-6}$ C is at the origin and positive point charge $q_2 = +6.0 \times 10^{-6}$ C is on the $-x$ -axis at $x = -0.20$ m.

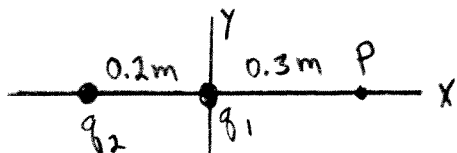

a) What is the magnitude and direction ($+x$ or $-x$) of the net electric field produced by these two charges at the point P that is on the $+x$ -axis at $x = +0.30$ m?

Ans. $E = \underline{5.84 \times 10^5 \text{ N/C}}$

direction $-x$

b) What is the electric potential at point P produced by these two charges? (Take the potential to be zero at very large distances from the charges.)

Ans. $-1.32 \times 10^5 \text{ V}$

(10 pts) 2.

a) In a region of space there is a uniform electric field with magnitude 800 N/C and that is in the $+x$ -direction. If the electric potential at the origin is 300 V , what is the electric potential at a point that is on the $-x$ -axis at $x = -0.50 \text{ m}$?

Ans. +700 V

b) A particle with charge $q = -8.0 \times 10^{-3} \text{ C}$ is released from rest at point a . When the particle reaches point b , 5.0 m to the right of point a , its kinetic energy is 4.0 J . The only force acting on the particle is the electric force. If the electric potential at point a is 300 V , what is the electric potential at point b ?

Ans. +800 V

(12 pts) 3.

a) Three capacitors are connected to a battery as shown in the sketch. $C_1 = 4.0 \times 10^{-6}$ F, $C_2 = 2.0 \times 10^{-6}$ F, and $C_3 = 3.0 \times 10^{-6}$ F. The charge Q_1 on C_1 is $Q_1 = 6.0 \times 10^{-4}$ C. What is the charge on each of the other two capacitors and what is the emf of the battery?

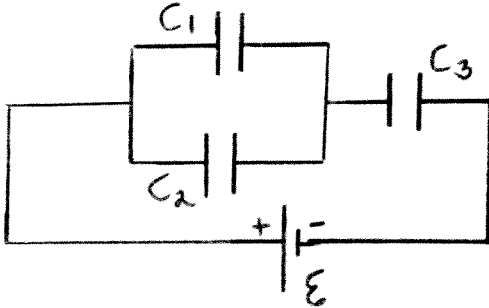

Ans. $Q_2 = \underline{3.0 \times 10^{-4} \text{ C}}$

$Q_3 = \underline{9.0 \times 10^{-4} \text{ C}}$

emf = $\underline{450 \text{ V}}$

b) Three resistors are connected to a battery as shown in the sketch. $R_1 = 4.0 \Omega$, $R_2 = 2.0 \Omega$, and $R_3 = 3.0 \Omega$. The voltage across R_1 is $V_1 = 36$ V. What is the voltage across each of the other two resistors and what is the emf of the battery?

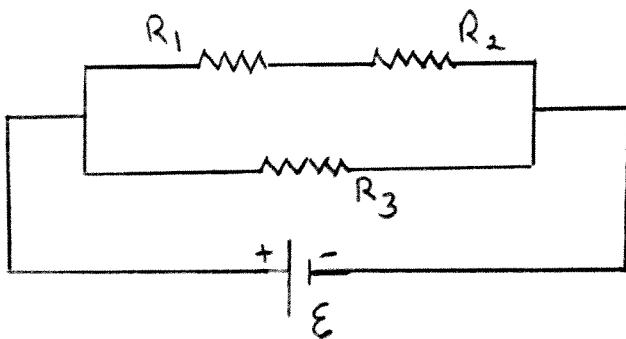

Ans. $V_2 = \underline{18 \text{ V}}$

$V_3 = \underline{54 \text{ V}}$

emf = $\underline{54 \text{ V}}$

(8 pts) 4. Consider the circuit shown in the sketch. Note that two currents are shown. Calculate the two battery emfs, \mathcal{E}_1 and \mathcal{E}_2 .

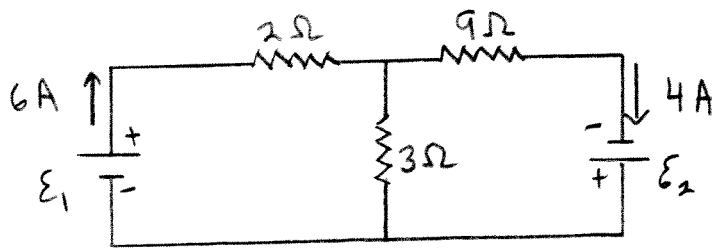

Ans. \mathcal{E}_1 18 V
 \mathcal{E}_2 30 V

(6 pts) 5. Consider the circuit shown in the sketch. $C = 5.0 \times 10^{-6}$ F and $L = 0.30$ H. Initially the switch S is open, there are no currents, and there is no charge on the capacitor. Then the switch is closed.

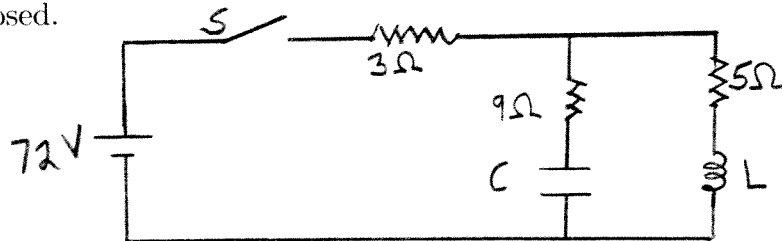

a) Just after the switch is closed, what is the voltage across the 3Ω resistor?

Ans. 18 V

b) After the switch has been closed a long time, what is the voltage across the 3Ω resistor?

Ans. 27 V

(8 pts) 6. A circular loop of wire has radius $r = 0.20$ m and resistance 40Ω . The loop is in a uniform magnetic field that is directed out of the plane on the paper, as shown in the sketch. The magnetic field is decreasing at a constant rate of $\Delta B/\Delta t = -0.050$ T/s. What are the magnitude and direction (clockwise or counterclockwise) of the current that is induced in the loop?

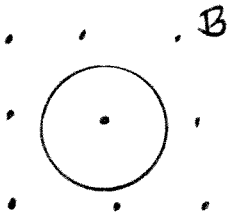

Ans. $I = \underline{1.57 \times 10^{-4} \text{ A}}$

direction counterclockwise

(9 pts) 7. Two long, straight parallel wires carry currents as shown in the sketch. The distance between the wires is 0.040 m. A small object with negative charge $q = -5.0 \times 10^{-4}$ C is moving parallel to the wires, in the opposite direction to the currents, with speed $v = 7.0 \times 10^4$ m/s. What are the magnitude and direction of the net force that the magnetic field of the two wires exerts on q ?

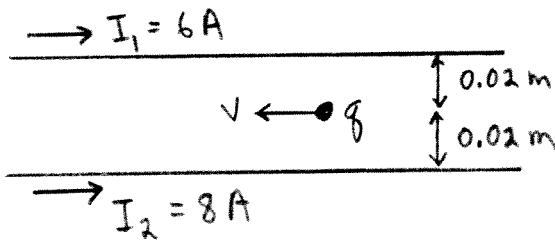

Ans. $F = \underline{7.0 \times 10^{-4} \text{ N}}$

direction ↓ toward bottom of page

(9 pts) 8. A series *ac* circuit has a source with voltage amplitude $V = 120$ V and angular frequency $\omega = 50$ rad/s, a resistor with $R = 15$ Ω and an inductor with $L = 0.40$ H.

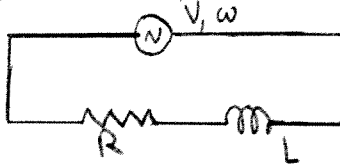

a) What is the current amplitude?

Ans. 4.8 A

b) What is the phase angle? Does the source voltage lag or lead the current?

Ans. phase angle 53.1°

lag or lead leads

c) What is the rate at which the source is delivering electrical energy to the circuit?

Ans. 173 W

(6 pts) 9. An object that is 2 mm tall is placed 40 cm to the left of a thin lens that has $f = +30$ cm.

a) Is the image real or virtual?

Ans. real

b) Is the image upright or inverted?

Ans. inverted

c) What is the height of the image?

Ans. 6 mm

(8 pts) 10. An oil film that is 400 nm thick is on top of water. The oil has $n = 1.2$ and the water has $n = 1.33$. White light in air is incident normal to the surface of the oil. What wavelengths in air within the limits of the visible spectrum ($\lambda = 400$ nm to 700 nm) have destructive interference between the light that is reflected from the upper and lower surfaces of the oil film?

Ans. 640 nm

(6 pts) 11. A portion of Table 30.2 Atomic Masses of Light Elements from the textbook is reproduced below. Use the information in the table to calculate the total binding energy of the nucleus ${}^9_4\text{Be}$.

TABLE 30.2 Atomic masses of light elements

Element	Atomic number, Z	Neutron number, N	Atomic mass, u	Mass number, A
Hydrogen, H	1	0	1.007825	1
Deuterium, H	1	1	2.014101	2
Helium, He	2	1	3.016029	3
Helium, He	2	2	4.002603	4
Lithium, Li	3	3	6.015123	6
Lithium, Li	3	4	7.016005	7
Beryllium, Be	4	5	9.012182	9

Ans. 58.2 MeV

(8 pts) 12. The gold nucleus ${}^{198}_{79}\text{Au}$ undergoes α -decay with a half-life of 2.70 days.

a) How many neutrons are there in the daughter nucleus that is produced by this decay?

Ans. 117

b) What is the activity in Bq (decays/sec) of a sample that contains 5.0 grams of ${}^{198}_{79}\text{Au}$ nuclei?

Ans. 4.49×10^{16} Bq